

致尊敬的顾客

---

## 关于产品目录等资料中的旧公司名称

---

NEC电子公司与株式会社瑞萨科技于2010年4月1日进行业务整合（合并），整合后的新公司暨“瑞萨电子公司”继承两家公司的所有业务。因此，本资料中虽还保留有旧公司名称等标识，但是并不妨碍本资料的有效性，敬请谅解。

瑞萨电子公司网址：<http://www.renesas.com>

2010年4月1日  
瑞萨电子公司

【发行】瑞萨电子公司（<http://www.renesas.com>）

【业务咨询】<http://www.renesas.com/inquiry>

## Notice

1. All information included in this document is current as of the date this document is issued. Such information, however, is subject to change without any prior notice. Before purchasing or using any Renesas Electronics products listed herein, please confirm the latest product information with a Renesas Electronics sales office. Also, please pay regular and careful attention to additional and different information to be disclosed by Renesas Electronics such as that disclosed through our website.
2. Renesas Electronics does not assume any liability for infringement of patents, copyrights, or other intellectual property rights of third parties by or arising from the use of Renesas Electronics products or technical information described in this document. No license, express, implied or otherwise, is granted hereby under any patents, copyrights or other intellectual property rights of Renesas Electronics or others.
3. You should not alter, modify, copy, or otherwise misappropriate any Renesas Electronics product, whether in whole or in part.
4. Descriptions of circuits, software and other related information in this document are provided only to illustrate the operation of semiconductor products and application examples. You are fully responsible for the incorporation of these circuits, software, and information in the design of your equipment. Renesas Electronics assumes no responsibility for any losses incurred by you or third parties arising from the use of these circuits, software, or information.
5. When exporting the products or technology described in this document, you should comply with the applicable export control laws and regulations and follow the procedures required by such laws and regulations. You should not use Renesas Electronics products or the technology described in this document for any purpose relating to military applications or use by the military, including but not limited to the development of weapons of mass destruction. Renesas Electronics products and technology may not be used for or incorporated into any products or systems whose manufacture, use, or sale is prohibited under any applicable domestic or foreign laws or regulations.
6. Renesas Electronics has used reasonable care in preparing the information included in this document, but Renesas Electronics does not warrant that such information is error free. Renesas Electronics assumes no liability whatsoever for any damages incurred by you resulting from errors in or omissions from the information included herein.
7. Renesas Electronics products are classified according to the following three quality grades: “Standard”, “High Quality”, and “Specific”. The recommended applications for each Renesas Electronics product depends on the product’s quality grade, as indicated below. You must check the quality grade of each Renesas Electronics product before using it in a particular application. You may not use any Renesas Electronics product for any application categorized as “Specific” without the prior written consent of Renesas Electronics. Further, you may not use any Renesas Electronics product for any application for which it is not intended without the prior written consent of Renesas Electronics. Renesas Electronics shall not be in any way liable for any damages or losses incurred by you or third parties arising from the use of any Renesas Electronics product for an application categorized as “Specific” or for which the product is not intended where you have failed to obtain the prior written consent of Renesas Electronics. The quality grade of each Renesas Electronics product is “Standard” unless otherwise expressly specified in a Renesas Electronics data sheets or data books, etc.
  - “Standard”: Computers; office equipment; communications equipment; test and measurement equipment; audio and visual equipment; home electronic appliances; machine tools; personal electronic equipment; and industrial robots.
  - “High Quality”: Transportation equipment (automobiles, trains, ships, etc.); traffic control systems; anti-disaster systems; anti-crime systems; safety equipment; and medical equipment not specifically designed for life support.
  - “Specific”: Aircraft; aerospace equipment; submersible repeaters; nuclear reactor control systems; medical equipment or systems for life support (e.g. artificial life support devices or systems), surgical implantations, or healthcare intervention (e.g. excision, etc.), and any other applications or purposes that pose a direct threat to human life.
8. You should use the Renesas Electronics products described in this document within the range specified by Renesas Electronics, especially with respect to the maximum rating, operating supply voltage range, movement power voltage range, heat radiation characteristics, installation and other product characteristics. Renesas Electronics shall have no liability for malfunctions or damages arising out of the use of Renesas Electronics products beyond such specified ranges.
9. Although Renesas Electronics endeavors to improve the quality and reliability of its products, semiconductor products have specific characteristics such as the occurrence of failure at a certain rate and malfunctions under certain use conditions. Further, Renesas Electronics products are not subject to radiation resistance design. Please be sure to implement safety measures to guard them against the possibility of physical injury, and injury or damage caused by fire in the event of the failure of a Renesas Electronics product, such as safety design for hardware and software including but not limited to redundancy, fire control and malfunction prevention, appropriate treatment for aging degradation or any other appropriate measures. Because the evaluation of microcomputer software alone is very difficult, please evaluate the safety of the final products or system manufactured by you.
10. Please contact a Renesas Electronics sales office for details as to environmental matters such as the environmental compatibility of each Renesas Electronics product. Please use Renesas Electronics products in compliance with all applicable laws and regulations that regulate the inclusion or use of controlled substances, including without limitation, the EU RoHS Directive. Renesas Electronics assumes no liability for damages or losses occurring as a result of your noncompliance with applicable laws and regulations.
11. This document may not be reproduced or duplicated, in any form, in whole or in part, without prior written consent of Renesas Electronics.
12. Please contact a Renesas Electronics sales office if you have any questions regarding the information contained in this document or Renesas Electronics products, or if you have any other inquiries.

(Note 1) “Renesas Electronics” as used in this document means Renesas Electronics Corporation and also includes its majority-owned subsidiaries.

(Note 2) “Renesas Electronics product(s)” means any product developed or manufactured by or for Renesas Electronics.

16

## R8C 2A/B Washer Platform

R8C Series – Flash MCU

### Microcomputer Development Environment System



# R8C 2A/B Washer Platform

R5F212ACSNFA

R5F212BCSNFA

## User's Manual

### RS-SH

#### 1<sup>st</sup> Edition

Published by: Renesas System Solutions (Beijing) Co., Ltd. Shanghai Branch.

Date: March 5, 2008 Version 1.01

Copyright(C): Renesas System Solutions (Beijing) Co., Ltd. Shanghai Branch. All rights reserved.

#### Trademarks

##### a) General

All brand or product names used in this manual are trademarks or registered trademarks of their respective companies or organizations.

##### b) Specific

Microsoft Windows is registered trademarks of Microsoft Corporation.

Pentium is a registered trademark of Intel.

## IMPORTANT INFORMATION

- ✧ **READ** this user's manual before using this platform board.
- ✧ **KEEP** the user's manual handy for future reference.

**Do not attempt to use the platform board until you fully understand its layout concept.**

### **MCU:**

Throughout this document, the term "Platform" shall be defined as the Renesas R8C 2A/B washer platform, which is for washing machine demo and prototype design reference.

### **Improvement Policy:**

Renesas System Solutions (Beijing) Co., Ltd. Shanghai Branch (hereafter collectively referred to as Renesas) pursues a policy of continuing improvement in design, performance, and safety of this evaluation board. Renesas reserves the right to change, wholly or partially, the specifications, design, user's manual, and other documentation at any time without notice.

### **Target User of the Product:**

Those who have carefully read and thoroughly understood the information as well as restrictions contained in the user's manual should only use this product. Do not attempt to use the product until you fully understand its mechanism.

### **Support:**

Regarding support for the product, no services will be provided.

## LIMITED WARRANTY

Renesas warrants its products to be manufactured in accordance with published specifications and free from defects in material and/or workmanship. The foregoing warranty does not cover damage caused by fair wear and tear, abnormal store condition, incorrect use, accidental misuse, abuse, neglect, corruption, misapplication, addition or modification or by the use with other hardware or software, as the case may be, with which the product is incompatible. No warranty of fitness for a particular purpose is offered. The user assumes the entire risk of using the product. Any liability of Renesas is limited exclusively to the replacement of defective materials or workmanship.

## DISCLAIMER

RENEASAS MAKES NO WARRANTIES, EITHER EXPRESS OR IMPLIED, ORAL OR WRITTEN, EXCEPT AS PROVIDED HEREIN, INCLUDING WITHOUT LIMITATION. THEREOF, WARRANTIES AS TO MARKETABILITY, MECRCHANTABILITY, FITNESS FOR ANY PARTICULAR PURPOSE OR USE, OR AGAINST INFRINGEMENT OF ANY PATENT. IN NO EVENT SHALL RENESAS BE LIABLE FOR ANY DIRECT, INCIDENTAL OR CONSEQUENTIAL DAMAGES OF ANY NATURE, OR LOSSES OR EXPENSES RESULTING FROM ANY DEFECTIVE PRODUCT, THE USE OF ANY PRODUCT OR ITS DOCUMENTATION, EVEN IF ADVISED OF THE POSSIBILITY OF SUCH DAMAGES. EXCEPT AS EXPRESSLY STATED OTHERWISE IN THIS WARRANTY, THIS PRODUCT IS SOLD "AS IS". AND YOU MUST ASSUME ALL RISK FOR THE USE AND RESULTS OBTAINED FROM THE PRODUCT.

**All Right Reserved:**

This user's manual and product are copyrighted and all rights are reserved by Renesas. No part of this user's manual, all or part, any be reproduced or duplicated in any form, in hardcopy or machine-readable form, by any means available without Renesas's prior written consent.

**Other Important Things to Keep in Mind:**

1. Circuitry and other examples described herein are meant merely to indicate the characteristics and performance of Renesas Technology's semiconductor products. Renesas assumes no responsibility for any intellectual property claims or other problems that may result from applications based on the examples described herein.
2. No license is granted by implication or otherwise under any patents or other rights of any third party or Renesas.
3. MEDICAL APPLICATIONS: Renesas Technology's products are not authorized for use in MEDICAL APPLICATIONS without the written consent of the appropriate officer of Renesas Technology (Asia Sales company). Such use includes, but is not limited to, use in life support systems. Buyers of Renesas Technology's products are requested to notify the relevant Renesas Technology (Asia Sales offices) when planning to use the products in MEDICAL APPLICATIONS.

**Limited Anticipation of Danger:**

Renesas cannot anticipate every possible circumstance that might involve a potential hazard. The warnings in this user's manual and on the product are therefore not all inclusive. Therefore, you must use the product safely at your own risk.



## PREFACE

### **About this manual**

This user's manual is written for Washing Machine platform using Renesas R8C 2A/B. It describes using of platform board and operation specification of washer software. Please use this user's manual to understand on how to operate the platform board, which also can help user to be familiar with Renesas R8C series MCU for washing machine application.

### **Section 1 About this platform**

Gives an general notification about using the emulation platform

### **Section 2 User interface**

Describes the user interface such as LCD & Led display, jumpers and keys.

### **Section 3 Operation**

This part introduces the washer platform program executing and operation logic.

### **Section 4 Software realization**

This part introduces the MCU resource using and software realization strategy.

### **Appendix:**

Washer platform program table

## Contents

1. About this platform.....	10
1.1 Platform general introduction .....	10
2.1 Washing Function Outline .....	11
1.2 Platform overview.....	12
1.3 Platform board introduction.....	13
1.3.1 LCD display function and setting introduction.....	13
1.3.2 Available interface introduction .....	14
1.3.3 AC driving output port introduction .....	15
1.3.4 Key and jumper input port introduction .....	16
2. User interface.....	18
2.1 Platform key introduction .....	18
2.1.1 “ Power ” key introduction .....	18
2.1.2 “ Start / Stop ” key introduction.....	19
2.1.3 “ Program ” key introduction.....	19
2.1.4 “ Function ” key introduction .....	19
2.1.5 “ Water Level ” key introduction.....	20
2.1.6 “ + ” & “ - ” key introduction .....	20
2.1.7 “ OK ” & “ Cancel ” key introduction.....	20
2.2 Platform LCD display introduction .....	20
2.2.1 Program setting menu .....	21
2.2.2 Running parameter option menu.....	21
2.2.3 Dedicated parameter setting menu.....	22
2.2.3 Platform running status display menu .....	25
2.2.4 Function setting menu introduction .....	25
2.2.5 Cover page menu introduction.....	26
2.2.5 Save water menu introduction .....	26
2.2.5 Error menu introduction.....	26
2.3 Jumper introduction .....	27
2.4 LED indicator .....	27
2.5 Automatic weight/texture detection.....	28
2.6 Water level detection .....	28
2.7 Buzzer .....	29
3. Operation .....	30
3.1 Modes of Operation .....	30
3.1.1 Platform running mode .....	30

---

3.1.2 Platform running status.....	30
3.2 Washing function introduction .....	31
3.2.1 Water supply process (Inlet).....	31
3.2.2 Drain process .....	32
3.2.3 Soak process .....	32
3.2.4 Wash process .....	33
3.2.5 Rinse process .....	33
3.2.5 Spin process .....	34
3.2.6 Error detection and alarm .....	35
3.2.7 Washing stream.....	35
3.2.8 Softener inlet.....	36
3.2.9 Platform demo program .....	36
3.2.10 Power down recovery .....	36
4. Software Realization.....	37
4.1 MCU resource arrangement.....	37
4.2 Washing program structure introduction .....	38
5. Using the Platform.....	41
5.1 Platform emulation and debugging.....	41
5.2 Test AC output with loading.....	42
5.3 Test unexpected power down recovery function .....	43
Appendix:.....	44

## 1. About this platform

### 1.1 Platform general introduction

- ❑ This platform is designed for washing machine software validation and emulation, and it can be used as prototype or reference platform for actual washing machine design. The function this platform realized is introduced in the following part of this manual.
- ❑ To simulate the washer functions, Jumpers and LEDs are used to represent some actual sensor inputs and outputs control. And we also realized all the actual washer function in hardware design, which can help customer enable their needed function very conveniently.
- ❑ For the AC driving part, All of the **triacs** used on this platform is **Renesas triac** products that well match consumer and home appliance electrical characters and requirement, customer can do the testing and evaluation very conveniently with this platform.

## 1.1 Washing Function Outline

- 1), LCD display (192 x 64 dots)
- 2), Error detection and alarming
- 3), Auto power off function
- 4), Voice module interface
- 5), Weight/texture detection
- 6), Water level detection
- 7), Automatism washing program
- 8), Unbalance detection and correct
- 9), Tube dry function
- 10), Preset function
- 11), Serial communication
- 12), A/D for analog input processing
- 13), I2C EEPROM communication

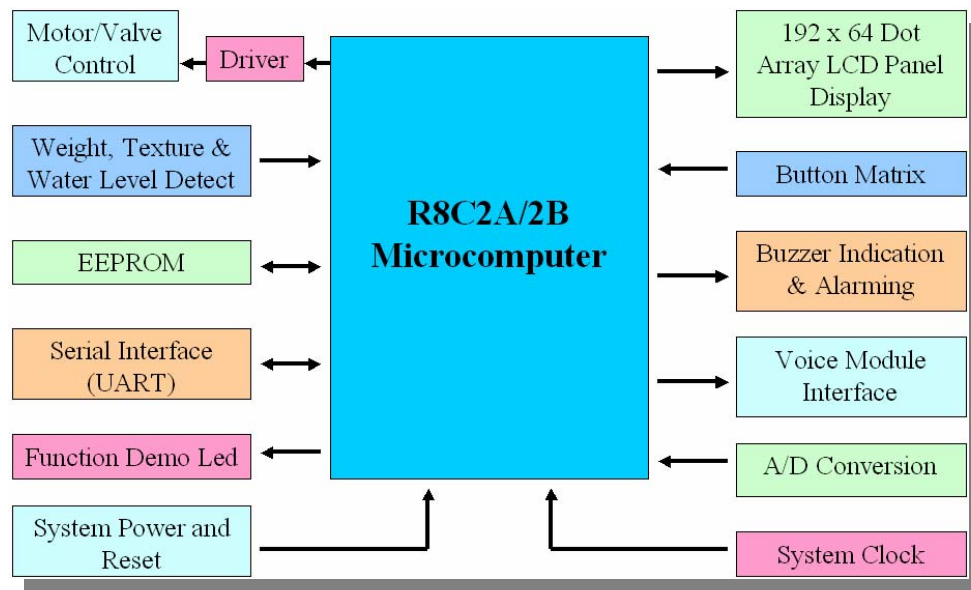

## 1.2 Platform overview

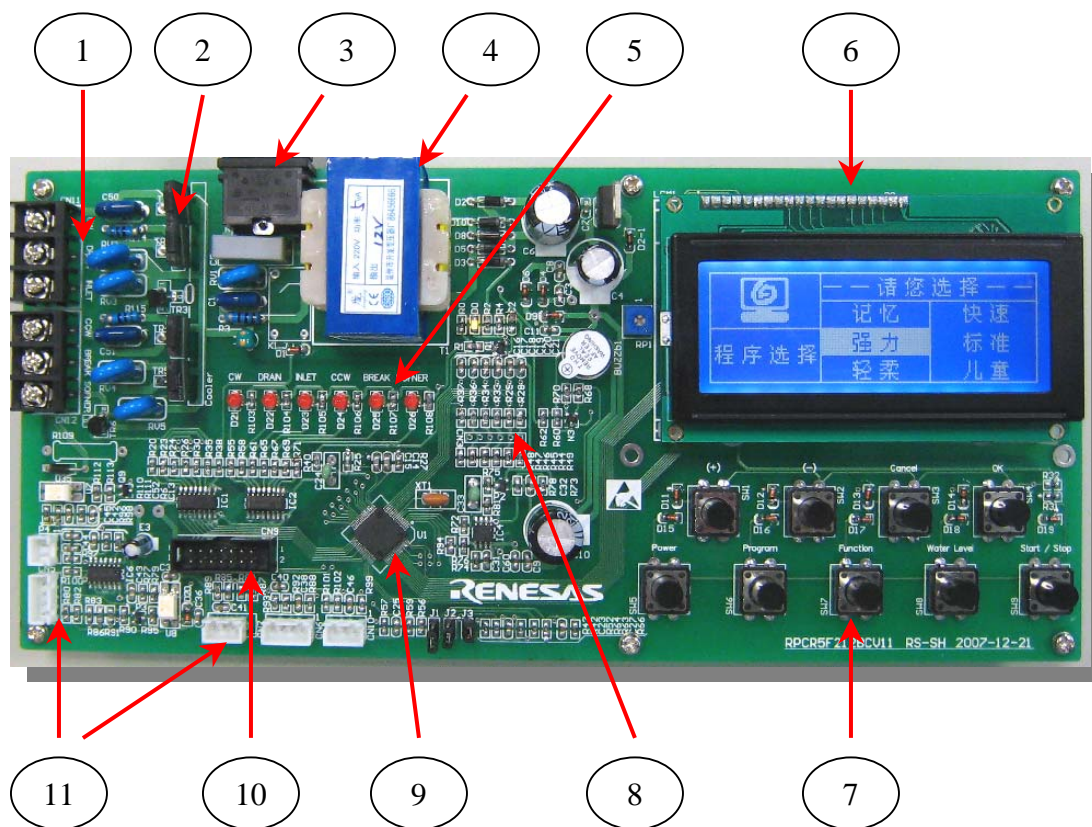

### Notes:

- 1, AC driving output portion, including washer motor driving and valve driving
- 2, **Renesas Triac** array, in this platform, especially, all the **triacs** use **Renesas** products
- 3, AC power input port. **AC power controller “K1” is not mounted on the board for security consideration because if “K1” switched on, system 5V is floating on 220V AC**
- 4, AC to DC transformer (220V AC ~ 12V DC)
- 5, AC driving output simulation LED array
- 6, Dot array LCD module (192 x 64 dots)
- 7, Key array for setting the platform
- 8, Voice interface (reserved)
- 9, R8C 2A/B MCU (R5F212ACSNFA or R5F212BCSNFA)
- 10, E8 emulator interface
- 11, Water level input, AD interface and UART interface

### 1.3 Platform board introduction

In this part, the function of the washer platform will be introduced and user can get to know how to use this platform as demo platform or as reference for new model design because this platform enable or at least reserve even all the peripheral function modules of **Renesas MCU R8C 2A/B**. Father more, we specially unutilized **Renesas Triac** as the AC driving output control, which is idea for washer application, we provide them on the platform for customer evaluation and testing.

#### 1.3.1 LCD display function and setting introduction

The LCD display contain 4 levels of menu, the first level is automatic washing program setting menu; the second level is parameter setting menu for selected program; the third level is dedicated water level, special function, and dedicated time parameter setting; the fourth level is washer program running status displaying menu, in which user can browse the detail program setting. Below is the example of each level of the menu.

1), First level menu, this level contains 2 pages which show the available program items and allows user to select which washing program the platform will run by pressing “confirm” key, then the LCD displays the second level menus. Bu pressing “+” or “-” key user can shift the selection.

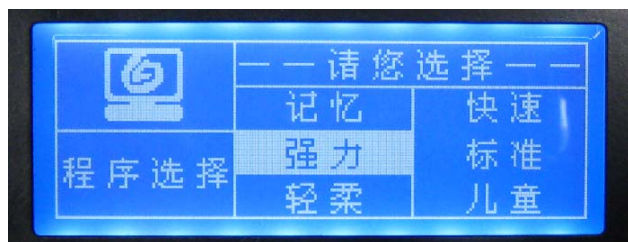

1. First level menu

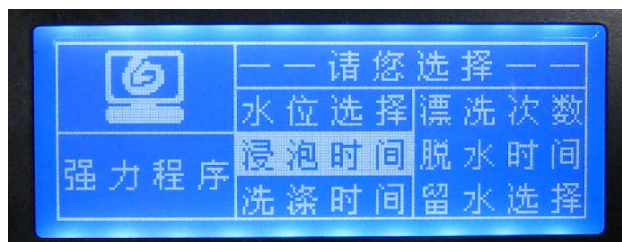

2. Second level menu

2), Second level menu, this level also contains 2 pages which show water level setting button, soak time setting button, wash time setting button, rinse time setting button, spin time setting button, save water button, and preset button, by pressing the “confirm” key, LCD will display the third level of menu, which is for detail washer running parameter selection. By pressing “+” or “-” key user can shift the selection.



3), Third level menu, this level contains 7 pages that show the detail washer running parameter setting, by pressing “+” or “-” key can select the available number of certain parameter such as water level, soak time, wash time and etc.

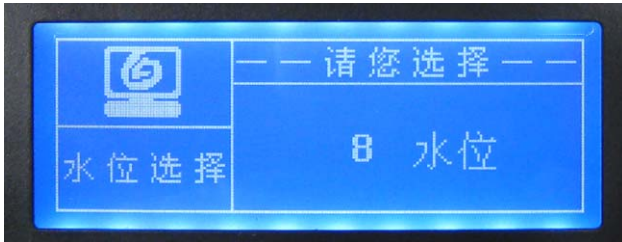

3. Third level menu

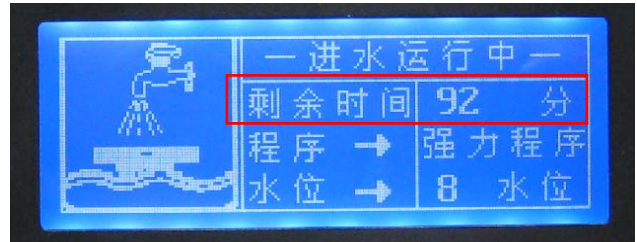

4. Fourth level menu

4), Fourth level menu, this level contains only 1 page which shows the platform running status, user can browse their setting by pressing “+” key, the highlighted area will change the content displayed accordingly.

### 1.3.2 Available interface introduction

Below picture shows the available interface provided or reserved for future using on this platform, for detail, please refer to the Notes.

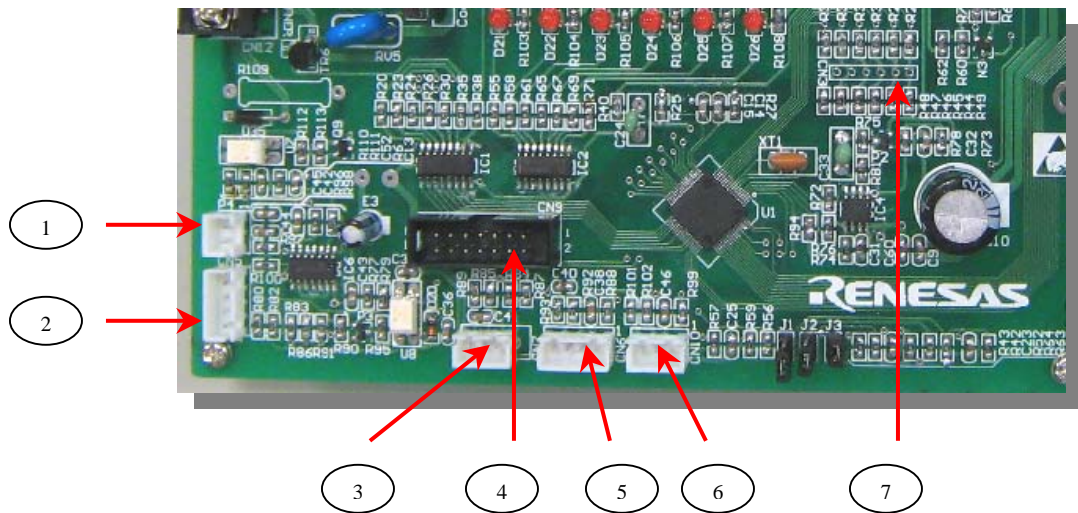



**Notes:**

- 1, Water level sensor input port
- 2, UART2 interface (use +5V logical level)
- 3, UART1 interface (use +5V logical level)
- 4, Renesas emulator E8 interface
- 5, AD interface (use AN1 port)
- 6, AD interface (use AN0 port)
- 7, Voice module interface (reserved, also can be use as other customized function)

**1.3.3 AC driving output port introduction**

Below picture shows the AC driving output ports and the function simulation LEDs, which include motor and valve AC driving output, for detail, please refer to the Notes.

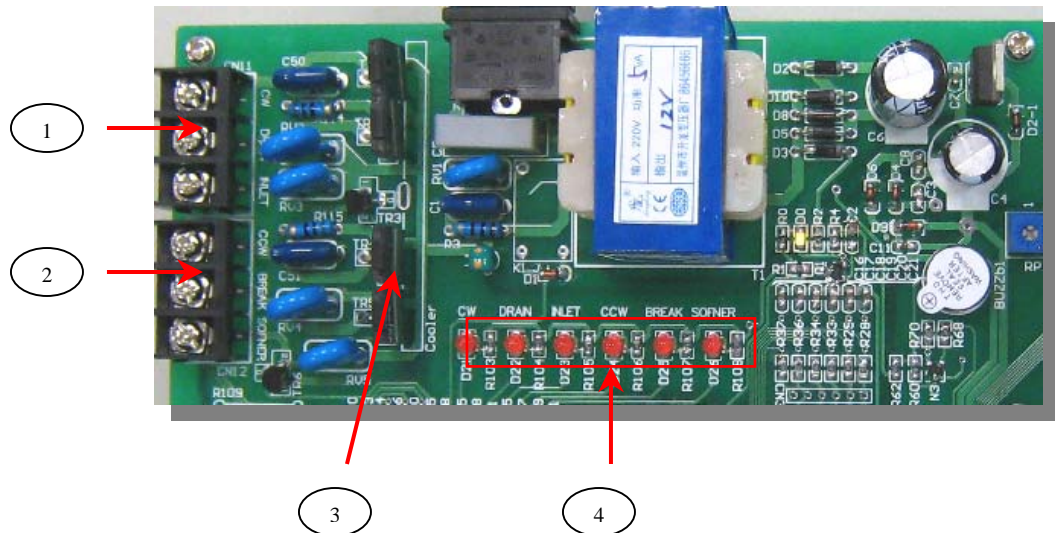

**Notes:**

- 1, AC driving output port (including CW, Drain, and Inlet output)
- 2, AC driving output port (including CCW, Softener, and Break output)
- 3, Renesas Triac array (BCR8PM-14LE, BCR2PM-14LE, BCR08AM-14A)
- 4, Function simulation LED (simulate the AC driving output functions)

### 1.3.4 Key and jumper input port introduction

Below picture shows the external jumpers and key array for setting the platform, the jumper is used to indicate currently the platform is in which status and the key is used to setting the running parameters in any kind of the status.



#### Notes:

- 1, **J1**: Door open / close status indication jumper, in demo mode, this jumper is used as door open / close detection; jumper “on” means door is closed; jumper “ off ” means door is open. In debugging mode, this jumper is used as water level input, “on” mean water reaches user setting value; “off” means water does not reach user setting value.
- 2, **J2**: Unbalance sensor input indication jumper, in demo mode, this jumper is used as unbalance detection; jumper “on” means unbalance happened; jumper “ off ” means unbalance not happened. In debugging mode, this jumper is used to decrease main “soak” and “wash” time, while this jumper switched “on” once and then switched “ off ”, the “soak” and “wash” time will be decreased to 30 seconds motor cycling, which can help user speed up system debugging and validation.
- 3, **J3**: Machine type selecting indication jumper, in demo mode, this jumper is reserved (this platform just use one type machine) for washing machine type selection function, by judging the jumper status, washer s/w can run different washing program. And in this platform, this

jumper is used for the s/w to determine which mode the platform is running after system power on; jumper “on” means platform is running in debugging mode, jumper “off” mean platform is running in demo mode.

- 4, Key input, including “ Power ”, “ Start / Stop ”, “ Program ”, “ Function ”, “ Water Level ”, “ + ”, “ - ”, “ Cancel ”, and “ OK ” key, for detail key functions, please refer to Part 2: User inter face.

## 2. User interface

### 2.1 Platform key introduction

This part will introduce platform key pressing rule and the LCD display function based on key and platform running status.

After “ Power ” key pressed, the platform is in initial mode, all key are valid, and during preset running, only “ + ” and “ Start / Stop ” key are valid. Below table shows the valid and invalid key in relative program running mode:

Key \ Status	Stand By	Initial	Run	Stop	Preset	Demo/ Debug Run
“ Power ”	○	○	○	○	○	○
“ Program ”	×	○	×	○	×	×
“ Function ”	×	○	×	○	×	×
“ Water Level ”	×	○	×	○	×	×
“ Start / Stop ”	×	○	○	○	○	○
“ + ”	×	○	○	○	○	○
“ - ”	×	○	×	○	×	×
“ Cancel ”	×	○	×	○	×	×
“ OK ”	×	○	×	○	×	×

#### 2.1.1 “ Power ” key introduction

When “ Power ” key pressed, the platform will run in “ Initial ” mode, all keys are valid for setting the platform.

- The platform will turn to “ Stand By ” mode if “ Start / Stop ” key have not been pressed within 5 minutes since any key pressed (or no key pressed) in this mode.
- When the program runs to the end, the platform will run to “ Stand By ” mode.

- ❑ In any mode expect “ Stand By ” mode, when “ Power ” key pressed, the platform with run into “ Stand By ” mode.
- ❑ The LCD backlight is turned off in “ Stand By ” mode.

In “ Initial ” mode, the LCD will display the first level menu, which allow user to select the dedicated washer program.

### 2.1.2 “ Start / Stop ” key introduction

The “ Start / Stop ” key change the platform running status like below:

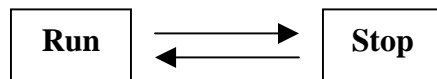

- ❑ While in “ Stop ”, all loading is off and the LCD displays the fourth level menu.
- ❑ While “Start / Stop” key pressed again, the program is resumed.

### 2.1.3 “ Program ” key introduction

When “ Program ” key pressed, the LCD display the first Level Menu and user can shift program selection button by pressing “ + ” or “ - ” key. Below figure shows the rule.

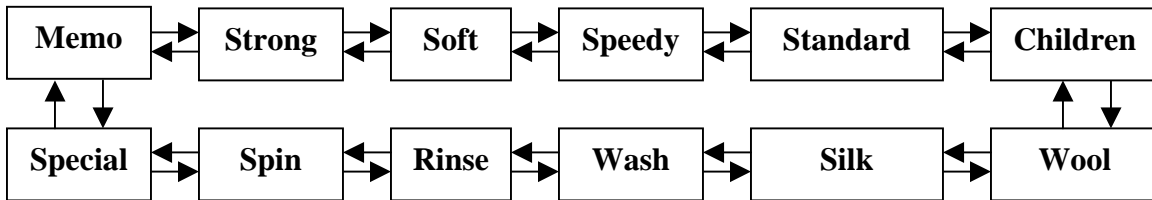

### 2.1.4 “ Function ” key introduction

When “ Function ” key pressed, the LCD display the third Level Menu and user can shift the function select button by pressing “ + ” or “ - ” key. Below figure shows the rule.

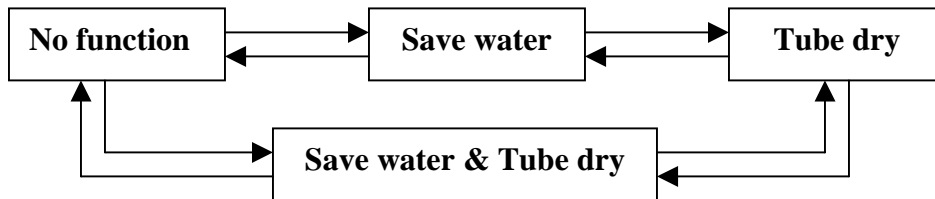

### 2.1.5 “ Water Level ” key introduction

When “Water Level” key pressed, the LCD displays the third Level Menu and user can shift the function selection button by pressing “ + ” or “ - ” key. There are 10 levels of water can be selected, from “ 1 ” to “ 10 ”, which increased by pressing “ + ” key and decreased by pressing “ - ” key.

During “ Soak ”, “ Wash ”, “ Rinse ” process is running, when “ Water Level ” key pressed, the inlet valve will be switched on and Inlet process running, after release “ Water Level ”key, the Inlet process stop and valve is switched off. However, if the water level is over protection level, this function is invalid.

The motor cycle stream will be changed according to the water level setting changed by user. When “ Speedy ” program selected, the default water level setting is “ 3 ” and cannot be changed.

In automatic washing program, the soak time is set by washing software according to the water level changing; in water level “ 1 ”, “ 2 ”, “ 3 ”, “ 4 ”, the soak time is 10 minutes; in water level “ 5 ”, “ 6 ”, “ 7 ”, the soak time is 20 minutes; in water level “ 8 ”, “ 9 ”, “ 10 ”, the soak time is 30 minutes.

Usually, the rinse water level is one level higher than wash water level, but if water level 10 selected, the rinse water level use the setting value.

### 2.1.6 “ + ” & “ - ” key introduction

User can shift the program or parameter setting button by pressing “ + ” or “ - ” key in relative level of the display menu, the highlighted items on LCD will roll over accordingly.

### 2.1.7 “ OK ” & “ Cancel ” key introduction

When “ OK ” key pressed, the selected program or parameter is set (on LCD, it’s the highlighted item), and the LCD menu display changed to the next level, and when the “ Cancel ” key pressed, the LCD menu level change back to the above level and allow user to re-select the program or parameter that have already been set.

## 2.2 Platform LCD display introduction

The platform LCD display have 4 levels of menu as described in the first part of this document, and there are many buttons in each of these menus, which can be highlighted by shifting the “ + ” or “ - ” key, then by pressing the “ OK ” key, user can select the dedicated function or the available parameters in current menu.



### 2.2.1 Program setting menu

This is the first level menu of the LCD display structure, and there are two pages and 12 buttons that delicately represent the available washing programs that can be executed by the platform. The default highlighted button is “Memo”, by pressing “+” or “-” key user can shift and highlight the relative button, which shows in below figure, then after user press “OK” key, the highlighted program is selected and the second level menu will display.



1, First page



2, Second page

**Note:** The special program can only be selected after the “Tubedry” function is enabled in “Function” setting menu.

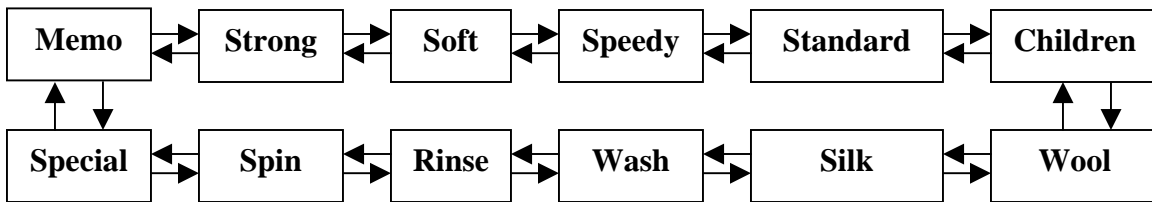

### 2.2.2 Running parameter option menu

This is the second level menu of the LCD display structure, and there are two pages and 7 buttons that represent the parameter option items. The default highlighted button is “Water Level”, by pressing “+” or “-” key user can shift and highlight the relative button, which shows in below figure. By pressing “OK” key, the next level menu will display.

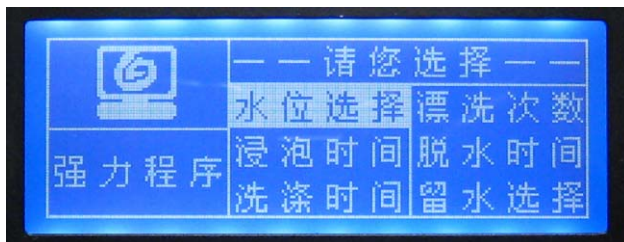

1, First page



2, Second page

Especially, the next level menus below “ Wash ”, “ Rinse ”, “ Spin ” and “ Special ” program are different from the normal parameter setting menu. The menu below “ Wash ” program just has “ Wash Time ” and “ Water Level ” options; the menu below “ Rinse ” program just has “ Rinse Time ”, “ Spin Time ” and “ Water Level ” options; the menu below “ Spin ” program just has “ Spin Time ” option; the menu after “ Special ” program just has “ Tubedry ” option. Please note that, after user select “ Tubedry ”, the LCD will go back to the first level menu.

**Note:** The save water function can only be selected after the “ Save Water ” function is enabled in “ Function ” setting menu.

### 2.2.3 Dedicated parameter setting menu

This is the third level menu of the LCD display structure, and there are 7 pages of menu that dedicatedly display the parameters according to the button that user selected in the second level menu. The default menu page is “ Water Level ”, by pressing “ + ” or “ - ” key user can shift up and down the available parameter values, then if “ OK ” key pressed, the current displayed value is selected and the LCD will set back to the above level menu for user to select other parameter options.

#### 2.2.3.1 Water level setting display

This is the menu page for user to set the water level during the washing program running. The default displayed value is “ Level 6 ”, by pressing “ + ” or “ - ” key user can shift up and down the available water level values from “ Level 1 ” to “ level 10 ”.

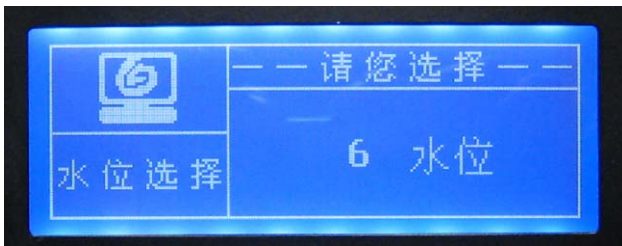

1, Water level setting



2, Soak time setting

#### 2.2.3.2 Soak time setting display

This is the menu page for user to set the soak time of selected washing program. The default displayed value is “ 0 minute ”, by pressing “ + ” or “ - ” key user can shift up and down the available soak time values from “ 0 minutes ” to “ 40 minutes ”.

#### 2.2.3.3 Wash time setting display



This is the menu page for user to set the wash time of the selected washing program. The default displayed value is “ 12 minutes ”, by pressing “ + ” or “ - ” key user can shift up and down the available wash time values from “ 0 minutes ” to “ 25 minutes ”.



1, Wash time setting



2, Rinse time setting

#### 2.2.3.4 Rinse time setting display

This is the menu page for user to set the Rinse time of the selected washing program. The default displayed value is “ 1 time ”, by pressing “ + ” or “ - ” key user can shift up and down the available rinse time values from “ 0 time ” to “ 4 times ”.

#### 2.2.3.5 Spin setting display

This is the menu page for user to set the spin time of the selected washing program. The default displayed value is “ 6 minutes ”, by pressing “ + ” or “ - ” key user can shift up and down the available spin time values from “ 0 minute ” to “ 9 minutes ”.



1, Spin time setting

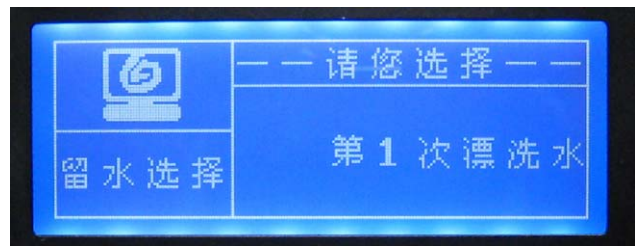

2, Save water setting

#### 2.2.3.6 Save water setting display

This is the menu page for user to set the save water function of the selected washing program. The default displayed value is “ The first time rinse water ”, by pressing “ + ” or “ - ” key user can shift up and down the available save water parameter values as below (cycle over):

“ The first time rinse water ” → “ The second time rinse water ” → “ The third time rinse water ”  
→ “ The first & second time rinse water ” → “ The second & third time rinse water ” → “ The  
first & second & third time rinse water ” → (no display) → “ The first time rinse water ” →...

If only two times or less rinse time selected, the display value will pass over the items that include the non-selected rinse time. For example, if only 2 times rinse selected, the display cycle is as below:

“ The first time rinse water ” → “ The second time rinse water ” → “ The first & second time  
rinse water ” → (no display) → “ The first time rinse water ” →...

While user select save water function, the drain process will be paused in the end of a rinse process, the buzzer buzzes 20 times (0.5s on 0.5s off) to indicate the save water is ongoing, and at the same time, platform LCD will display how many save water time is left during current program setting. After user press “ Start / Stop ” key, the drain valve is switched open and the washing program resumes. If user does not press the “ Start / Stop ” key within 4 hours, washing program will start the drain process and run the unfinished program.

For program left time calculation, if save water function selected, the time that the washer wait for user to release save water function is not included in the running time.

### 2.2.3.7 Preset setting display

This is the menu page for user to set the preset time of the selected washing program. The default displayed value is “ 2 hours ”, by pressing “ + ” or “ - ” key user can shift up and down the available preset running time from “ 2 hours ” to “ 24 hours ”; there is no “ 0 hour ” and “ 1 hour ” option, instead, after option “ 24 hours ” there is an no display items inserted before cycle to “ 2 hours ” option.

If “ OK ” key pressed, the preset function is enabled and the preset is running after “ Start / Stop ” key pressed; and the fourth level menu will display preset left time and other selected washing program parameters. The preset program start time is calculated using preset time subtracting the program longest running time and then adding 15 minutes.

During preset running, if “ Start / Stop ” key pressed, preset running is paused and washing program allows user to change the program setting. If “ Power ” key pressed, the preset running is canceled and platform is shut down, in this case, user needs to set again the washing program.

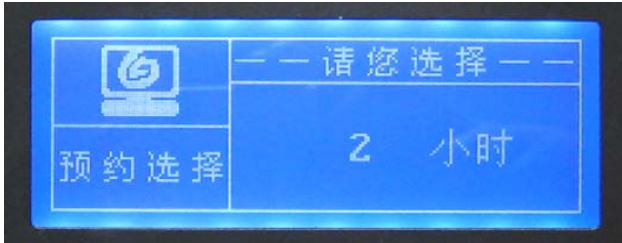

1, Preset time setting



2, Running status display

### 2.2.3 Platform running status display menu

This is the fourth level menu of the LCD display structure, and there is only 1 page that displays the washing program running status and user program setting. In this level menu, only “ Start / Stop ” key and “ + ” key are valid. By pressing “ + ” key, user can browse the selected program parameters; by pressing “ Start / Stop ” key, the program will paused and allows user to set again the washing program in stop status. The display content is as below by pressing “ + ” key in 4<sup>th</sup> level (cycle over):

“ Program left time ” → “ Soak time ” → “ Wash time ” → “ Rinse time ” → “ Spin time ”  
→ “ Function selected ” ...

### 2.2.4 Function setting menu introduction

This is the menu page for user to set the special function during the washing program running. The default setting is “ No function selected ”, by pressing “ + ” or “ - ” key user can shift up and down the available functions from “ No function selected ” to “ All function selected ”. Below figure shows the function selection setting rule.

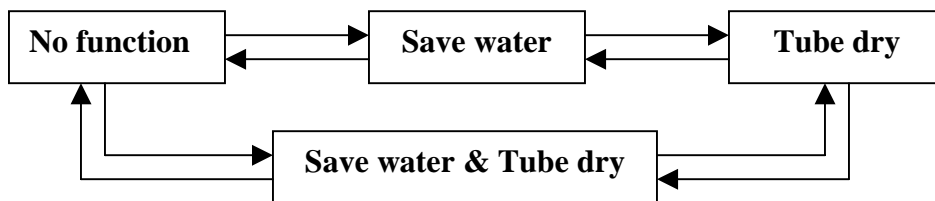

Below is the function setting menu page:

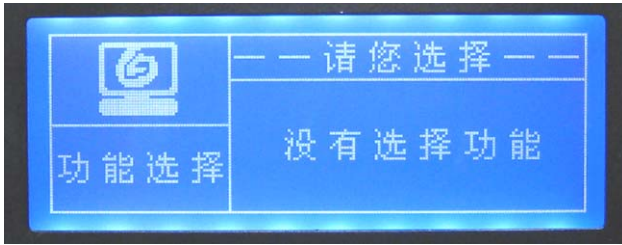

1, Function setting



2, Cover page

### 2.2.5 Cover page menu introduction

Actually, before the first level menu displayed, there is a cover page menu display, which shows Renesas company information. This page will show on screen for 3 seconds after “ Power ” key pressed in “ Stand By ” mode, then LCD will display the first level menu.

### 2.2.5 Save water menu introduction

When save water function selected, the washer program will not start the drain process in the end of selected rinse process. The buzzer will buzz to remind user the save water is happening, and LCD will display the save water page, the left times displayed includes current rinse time. Below shows the detail.



1, Save water display

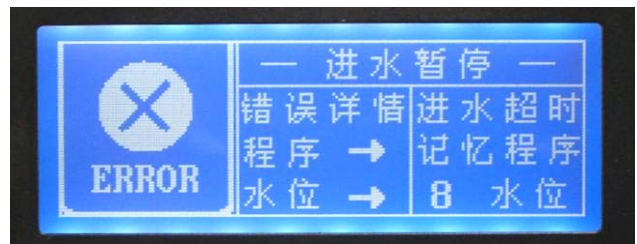

2, Error display

### 2.2.5 Error menu introduction

When error occurs, the washer program will pause current process and buzzer begin to alarming, and LCD will display the error status page; the detail error situation is also displayed. The above shows the error page while inlet error occurs.

## 2.3 Jumper introduction

On the platform, the 3 jumpers are used for detecting the external parameter value or the environment setting for the platform. Below describe the details:

JUMPs	Function Indicate	Comment
Jump 1 *	Water Level status	ON: Full      Off: Not full
Jump 2 *	Lid status	ON: Close      Off: Open
Jump 3 *	Demo mode selection	ON: Debugging mode Off: Demo mode

As platform running in debugging and demo mode, the jumper functions are different, below shows the function detail:

- ❑ J1: Door open / close status indication jumper, in demo mode, this jumper is used as door open / close detection; jumper “on” mean door is closed; jumper “ off ” mean door is open. In debugging mode, this jumper is used as water level input, “on” mean water reaches to user setting value; “off” means water does not reach user setting value.
- ❑ J2: Unbalance sensor input indication jumper, in demo mode, this jumper is used as unbalance detection; jumper “on” mean unbalance happened; jumper “ off ” mean unbalance not happened. In debugging mode, this jumper is used to decrease main “soak” and “wash” time, while this jumper switched “on” once and then switched “ off ”, the “soak” and “wash” time will be decreased to 30 seconds motor cycling, which can help user speed up system debugging and validation.
- ❑ J3: Machine type selecting indication jumper, in demo mode, this jumper is reserved (this platform just use one type machine) for washing machine type selection function, by judging the jumper status, washer s/w can run different washing program. And in this platform, this jumper is used for the s/w to determine which mode the platform is running after system power on; jumper “on” means platform is running in debugging mode, jumper “off” mean platform is running in demo mode.

## 2.4 LED indicator

The platform have 7 LEDs for displaying platform board power status and the AC output situation. Below table show the function of each LED:

LED	Function	Description
D0	Power led	While AC power connected and system 5V is ready, this led is on
D21	CW led	While this Led on, it indicates the CW triac is switched on.
D22	Drain led	While this Led on, it indicates the drain triac is switched on.
D23	Inlet led	While this Led on, it indicates the inlet triac is switched on.
D24	CCW led	While this Led on, it indicates the CCW triac is switched on.
D25	Reserved led	This Led is reserved for future function extension, which is named as "BREAK"
D26	Softener led	While this Led on, it indicates the CW triac is switched on.

## 2.5 Automatic weight/texture detection

This function have not been enabled in release version of platform s/w because this functions performance depends on the real washer motor type and features, so the platform just implement h/w of this function, which can be conveniently used or modified by customer.

## 2.6 Water level detection

In this platform, the s/w just use " 0 " and " 1 " to judge washer water level, " 0 " indicates the water does not reach user setting level, " 1 " indicates the water reached the user set value. We did not use the pulse type water level detection because this function also depends on customer side sensor and system hardware and mechanical features, thus as the same with weight and texture detection, we also implemented the h/w for pulse type water level detection.



## 2.7 Buzzer

The platform used one buzzer for washer running status indication and alarming. When “ Power ” key pressed, the buzzer will buzz one time; when save water function is executing, the buzzer will buzz 20 times (0.5 second on, 0.5 second off) every 15 minutes; and when system error happen, the buzzer will also buzz 20 times (0.5 second on, 0.5 second off) every 15 minutes. All these functions are described in relative part that use buzzer.

## 3. Operation

### 3.1 Modes of Operation

As the platform would be used as demo platform or prototype washer in test and validation, we set two kinds of mode that the platform can run by judging external jumper status.

#### 3.1.1 Platform running mode

The platform runs in modes:

**Debugging Mode:** In this mode, user can debug the platform s/w and the program running style is the same with real washer running style except that “ J1 ” and “ J2 ” is used as water and washing status detection.

**Demo Mode:** In this mode, after “ Power ” key pressed, the platform runs washer program automatically and when the program finished the platform will resume and run the same program again. During automatic program running, user can press “Start/Stop” key to pause the program and set the program manually, then by pressing “Start/Stop” key, the platform will run user set program and after user set program finished, the platform will run automatic program again.

#### 3.1.2 Platform running status

In any mode of the platform, the washer program would be in one of below statuses, according to these statuses, washer s/w run logically to execute washing machine functions.

**Stand By:** Waiting for “ Power ” key to turn on the controller; only power LED display are on. In this mode, the MCU is running.

**Initial:** The platform is ready for setting by user, by press “ Start / Stop ” key, the platform will begin to run user set program.

**Stop:** During the platform is running program, if “ Start / Stop ” key pressed, the platform will turn to “ Stop ” mode and all output are off.

**Run:** The platform is running user set program.

**Preset:** The platform is running in preset mode



### 3.2 Washing function introduction

This part introduces the washing program main function execution, which includes inlet, drain, soak, wash, rinse and spin process program operation. Below table shows the general guideline of washing program operation.

Process	AC Loading
Soak, Wash	Motor L, R Cycle
Rinse	Motor L, R Cycle
Inlet	Inlet Valve: ON
Drain	Drain Motor: ON
Intermittent spin	Drain Motor: ON    Motor R: ON/OFF Intermittently
Spin	Drain Motor: ON    Motor R: ON
Spray spin	Drain Motor: ON    Motor R: ON/OFF Intermittently Inlet Valve: ON/OFF Intermittently
Inertial spin	Drain Motor: ON    Motor R: OFF
Brake	Drain Motor: OFF    Motor R: OFF

#### 3.2.1 Water supply process (Inlet)

In this platform, the s/w just use “ 0 ” and “ 1 ” to judge washer water level, “ 0 ” indicates water does not reach user setting value, “ 1 ” indicates the water reached the user setting value. Below are the water supply function details:

- ❑ While inlet process starting, the Inlet triac switched on and supply water to user setting water level, the time set for inlet process is 2 minutes, while this process exceeds 2 minutes, washing program will stop time counting; and if this process finished in less than two minutes, the process running time still calculated as 2 minutes.
- ❑ While water level does not reach the user setting value in 20 minutes, platform will alarm and start to run error processing program.
- ❑ During “ soak ”, “ wash ” and “ rinse ” process, if water level drop one or more levels lower than user setting value, platform will pause current process and start inlet process, the process running time counting is stopped at this time. While the platform executing the last time rinse inlet, the softener inlet valve switched on for 10 seconds at the same time the inlet valve switched on. While water level does not reach the user setting value in 20 minutes, platform will alarm and start to run error processing program.

- ❑ At the first time inlet of the rinse-spin type, if water level failed to rise up 2 levels in 2 minutes, the program will change to normal type rinse instead of rinse-spin type.
- ❑ If user setting water level value is higher than the 4<sup>th</sup> level, while water reach to the 3<sup>rd</sup> level, washing program begin to run the next step process, and washing motor run with the corresponding stream based on the rising water level, which will last till water reaching user setting value.
- ❑ During inlet running, if lid is open, platform will alarm and run the error processing program.

### 3.2.2 Drain process

In drain process, the drain triac switched on till water is drained off, after that, the platform will keep draining for 60 seconds and then begins to run the next step process. The time set for drain process is 2 minutes, while this process exceeds 2 minutes, washing program will stop time counting; and if the process finished in less than two minutes, the process running time still calculated as 2 minutes.

If there is even no water in the tube at the beginning of drain process, the platform still keep draining for 10 seconds and then platform starts to run the next step process. If the tube has not been drained off in 8 minutes, platform will alarm and start to run error processing program.

### 3.2.3 Soak process

Based on the available soak time setting, washing program separate washing motor cycle time as 3 types and 4 kinds of combinations as below. During soak running, if lid is open, platform will alarm and run the error processing program.

- ❑ Below are the 3 types of the motor cycles:
  - A: 2 minutes motor cycle + 3 minutes stop
  - B: 1 minutes motor cycle + 4 minutes stop
  - C: 1 minutes motor cycle + 9 minutes stop
- ❑ Below are the 4 kinds of motor cycle combinations based on A, B and C motor cycle types:
  - a), 10 minutes group (A, B);
  - b), 20 minutes group (A, B, C);
  - c), 30 minutes group (A, B, C, C);
  - d), 40 minutes group (A, B, C, C, C);

### 3.2.4 Wash process

Wash process runs different type of motor cycles according to user selected washing programs. This part introduces wash process in relative program. For details, please refer to the program tables. During wash running, if lid is open, platform will alarm and run the error processing program.

a), In “ Standard ” program, wash process runs with below rules:

- ❑ If “ soak ” process selected, wash process starts the main stream washing motor cycle (motor cycling time use wash set time subtracting 30 seconds) and then runs 30 seconds balance washing motor cycle.
- ❑ If full automatic program enabled, the wash process runs as following procedure: Weight detection → Texture detection → Inlet for water drop → Wash for set time → Balance for 30 seconds. Especially, as we did not enable the weight and texture detection function in s/w, the platform will not distinguish whether or not the full automatic program is enabled.
- ❑ If the full automatic program not enabled, wash process starts the main stream washing motor cycle (motor cycling time use wash set time subtracting 30 seconds) and then runs 30 seconds balance washing motor cycle.

b), In “ Memo ”, “ Strong ” and “ Soft ” program, after inlet to user setting water level, wash process starts the main stream washing motor cycle (motor cycling time use wash set time subtracting 30 seconds) and then runs 30 seconds balance washing motor cycle.

c), In “ Wool ” and “ Silk ” program, after inlet to user setting water level, wash process starts the main stream washing motor cycle (motor cycling time use wash set time subtracting 30 seconds) and then runs 30 seconds balance washing motor cycle.

### 3.2.5 Rinse process

Rinse process has two types, one is rinse with water inlet to user setting level, and the other is rinse-spin type. For details, please refer to the program tables. During rinse running, if lid is open, platform will alarm and run the error processing program.

a), Rinse with water inlet to user setting water level:

- ❑ After inlet to user setting water level, wash process starts the main stream washing motor cycle (motor cycling time use wash set time subtracting 30 seconds) and then runs 30 seconds balance washing motor cycle.

b), Rinse-Spin type:

Washing program starts with spin process, and at the same time, the inlet valve open and close with 35/30 seconds cycles (for details, please refer to the program table).

### 3.2.5 Spin process

Spin process has four steps, there are intermittent spin, continuous spin, inertial spin and brake, and in some program the spin process may be with the inlet on (rinse-spin type). During spin running, if lid is open, platform will alarm and run the error processing program. Below is the description of the spin process.

a), In intermittent spin, the motor run clockwise with 4s/3s on/off cycles.

b), In continuous spin, the motor run clockwise continuously.

c), Spay spin is the process that during spin, the inlet valve open and close with 35/30 seconds cycles (for details, please refer to the program table).

d), In inertial spin, the motor is turned off with drain valve on, and the tube keep running by the inertial motion. If the lid is open, this process paused but it does not need to judge the balance status.

e), While brake occurs, drain valve and drain motor are turned off, this process lasts for 5 seconds, the tube is braked by the mechanical part.

f), While spin running, the washing motor keep turned off for 7 seconds after the drain motor and valve switched on for waiting the mechanical parts being ready.

g), During spin running, if lid is open or unbalance happen, platform will alarm and run the error processing program. At this time, washing motor is stopped and drain motor and valve is switched off, and the tube is braked by mechanical parts.

h), If unbalance happen, the program will stop spin process and inlet to user setting water level value, then starts wash process with balance stream for 60 seconds, after that, washing program will resume drain and spin process. If unbalance happen again after 2 times adjusting, platform will alarm and run the error processing program. During unbalance adjusting, the program left time will be increased accordingly.

### 3.2.6 Error detection and alarm

During washing program running, 8 type of error detection is enabled and the platform will start alarming and begin to run the error processing program if error occur. At this time, the LCD will display relative error status information. Below table shows the error type and detail information, especially, the error code is used by washer software but will not be displayed on LCD:

Error type	Description	Error code	Buzzing	Error release
Preset lid open	The lid is opened during preset program running	E0	20 times 0.5s/0.5s on off buzzing in every 15 minutes	Open and close lid one time
Abnormal Drain	Drain over 8 minutes	E1		
Abnormal lid open	At the starting moment of wash, rinse and spin process, the lid is open.	E2		
Abnormal spin	Spin unbalance happen	E3		
Abnormal inlet	Inlet over 20 minutes	E4		

### 3.2.7 Washing stream

The washing stream is defined by the washing motor on / off time cycles, below tables show the stream option in relative program running, which also is related to the AC power frequency.

Main stream		High	Middle	Low	Balance stream
Memo	50Hz	1.0/0.7	0.8/0.7	0.6/0.6	0.2/0.5
	60Hz	0.8/0.8	0.6/0.7	0.5/0.6	
Speedy	50Hz	/	/	0.7/0.7	
	60Hz	/	/	0.6/0.8	
Child	50Hz	0.9/0.7	0.7/0.7	0.5/0.6	
	60Hz	0.8/0.8	0.6/0.7	0.4/0.6	
Strong	50Hz	1.1/0.8	0.9/0.8	0.6/0.6	
	60Hz	0.9/0.8	0.8/0.8	0.5/0.6	
Standard	50Hz	1.0/0.7	0.8/0.7	0.6/0.6	
	60Hz	0.8/0.8	0.6/0.7	0.5/0.6	

Soft	50Hz	0.9/0.7	0.7/0.7	0.5/0.6	
	60Hz	0.8/0.8	0.6/0.7	0.4/0.6	
Wool	50Hz	0.4/0.6	0.3/0.6	0.2/0.6	None
	60Hz	0.3/0.6	0.2/0.6	0.1/0.6	

Below table shows strengthened stream option in “ Memo ”, “ Standard ”, “ Strong ” and “ Soft ” programs:

Strong stream	High		Middle		Low
	50Hz	60Hz	50Hz	60Hz	
Memo/Standard/Strong	1.4/0.6	1.2/0.6	1.2/0.5	1.0/0.6	None
Soft	1.3/0.6	1.1/0.6	1.1/0.5	0.9/0.6	

In these programs, the main stream and the strong stream executed alternately at high and middle water level, which is combined with 2 minutes main stream and 20 seconds strong steam.

### 3.2.8 Softener inlet

In the last time rinse, at the beginning of the inlet process, there is a 10 seconds softener inlet process at the same time with water inlet. Which is described in the inlet process.

### 3.2.9 Platform demo program

The platform will run demo program by when jumper 3 in “ off ” status. After “ Power ” key pressed, the program will run automatic washer program without user setting. During this mode, the platform will run automatic washer program repeatedly, which mean after finishing one time program running the platform will resume another time program running with the same setting.

### 3.2.10 Power down recovery

The platform enabled the power down recovery function using R8C 2A/2B MCU Voltage Detection function. For technical details, please refer to the schematic and s/w source code.

## 4. Software Realization

### 4.1 MCU resource arrangement

Below form introduces the resource arrangement of R8C 2A/2B MCU for this platform. The Schematic of the platform is attached at the end of this manual.

	Port	Pin	Comment
I/O port	Port 0	P00 ~ P03	LCD data line
		P04 ~ P05	LCD control line
	Port 1	P10-P13	LCD data line
		P14	Softener LED output control
		P15	Reserved LED control
		P16	Load testing input
		P17	Water level detection input
	Port 2	P20-P24	key scan output
		P25-P26	key scan input
		P27	Voice module control
	Port 3	P30	Drain triac control
		P31	Buzzer control output
		P32	INT2 input
		P33	Jmper1 input
		P34	Jmper2 input
		P35	Jmper3 input
		P36	CW triac control
P37		LCD backlight control	

	Port	Pin	Comment
I/O port	Port 4	P43 ~ P44	I2C bus for EEPROM R/W
		P45	CW triac control
	Port 5	P50 ~ P54	Voice module control
	Port 6	P61 ~ P62	LCD control line
		P63 ~ P64	UART communication
		P65	Inlet triac control
		P66 ~ P67	UART communication
	Port 8	P80	Softener triac control
		P81	AC power cutting off control
		P82	CW LED output control
		P83	Drain LED output control
		P84	Inlet LED output control
		P85	CCW LED output control
		P86	Reserved LED output control
A/D	AN0, AN1	P06 ~ P07	A/D conversion
Interrupt	Timer A	_____	Used as the system 4ms base timer
	Timer B	_____	Used as key scan and buzzer timer
	INT2	P32 / INT2	Used as AC frequency detection
	Vdet2	_____	Used to detect unexpected power down situation.

## 4.2 Washing program structure introduction

The figure below shows the platform s/w structure and almost all the functions in C source code, and the interrupt routine is also included.



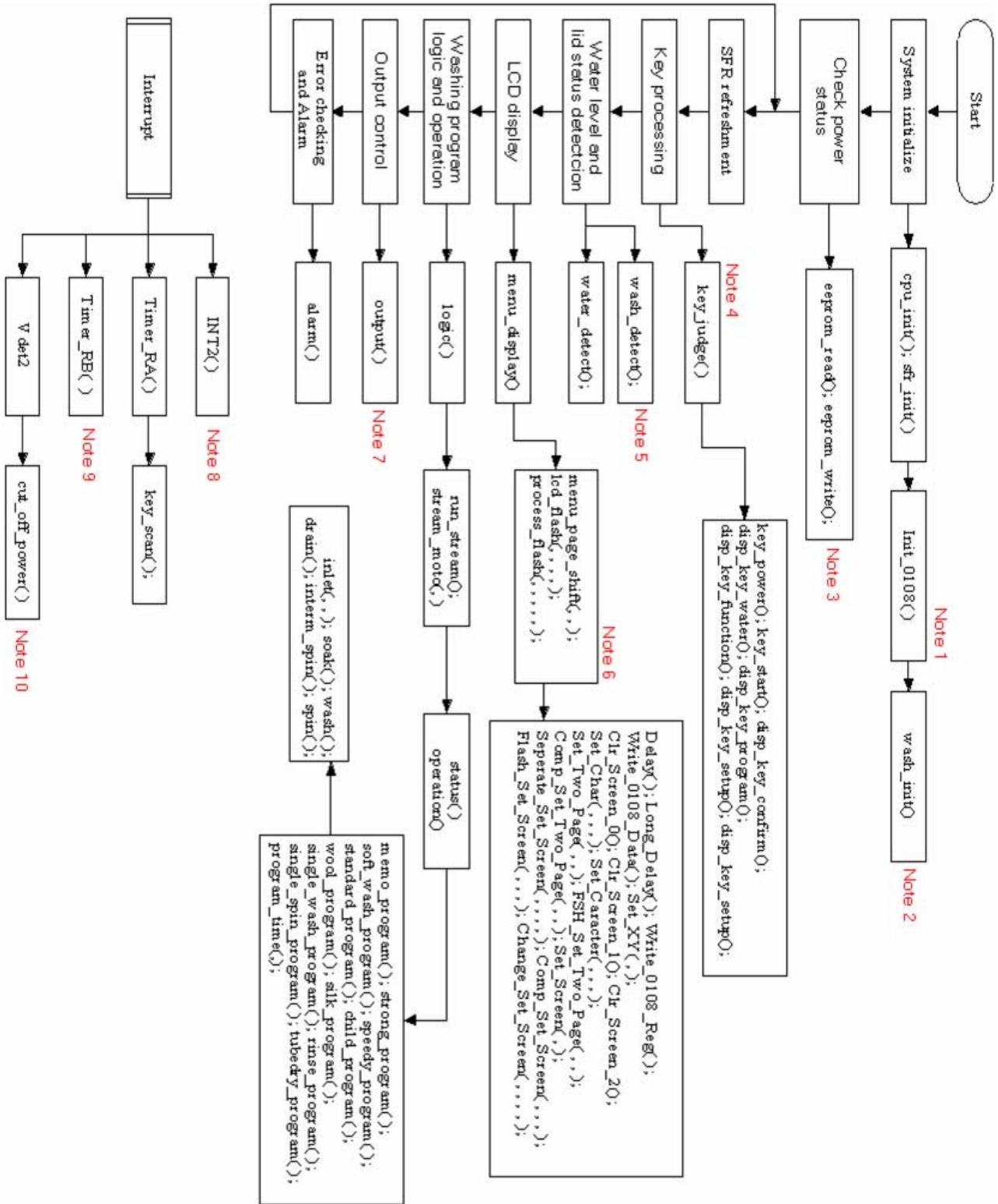

Below notes introduces above software structure figure, based on which user can get known of platform function software realization. The “ , ” in the C functions indicates corresponding function prototype has one or more arguments.

**Note:**

1, The “ Init\_0108() ” is the C function that initialize LCD and the variables of the LCD driver.

2, The “ wash\_init() ” is the C function that initialize all the variables used during platform running.

3, The “ eeprom\_read() ” is used to check platform power status and executes the power down recovery function if necessary, which is realized by reading the flag in certain address of the EEPROM, if the flag is “ 1 ”, it’s mean before current power on, there is an unexpected power down happened and power down recovery function need to be executed; if the flag is “ 0 ”, it’s mean current power on is an normal power on process.

The “ eeprom\_write() ” is used to copy the content in certain RAM address of R8C 2A/2B to EEPROM for saving the variables that is on using at the time of voltage detection interrupt occurs, and especially, this function sets the power status flag to indicate an unexpected power down happens. During power down recovery running, the saved variables will be write back to RAM of R8C 2A/2B.

4, The “ key\_judge ” function is used to handle user key pressing. In this function, the LCD display flags and system status flags were set.

5, “ wash\_detct ” is used in platform debugging mode, this function will detect the jumper 2 status and decide whether or not the “Soak ” and “ Wash ” will be decreased.

6, LCD display function use 3 functions, “ menu\_page\_shift(, ) ” is for screen page shifting; “ lcd\_flash(, , , ) ” is for flashing display during parameter setting; “ process\_flash(, , , , ) ” is for status display during washing program running, and these functions call relative LCD driver functions to refresh the screen.

7, The “output() ” function refresh the LED and triac output at in every loop of washing program running.

8, The “ INT2 () ” is used as AC frequency detection.

9, The “ Timer\_RB () ” is used for key scan and buzzer.

10, The “ cut\_off\_power ” is used to detect the unexpected power down situation.

## 5. Using the Platform

### 5.1 Platform emulation and debugging

In this part, the configuration of the platform emulation and debugging is introduced. Below figure shows system emulation environment with Renesas Hew and E8 debugger. For detail introduction, please refer to Renesas HEW and E8 debugger user manuals.

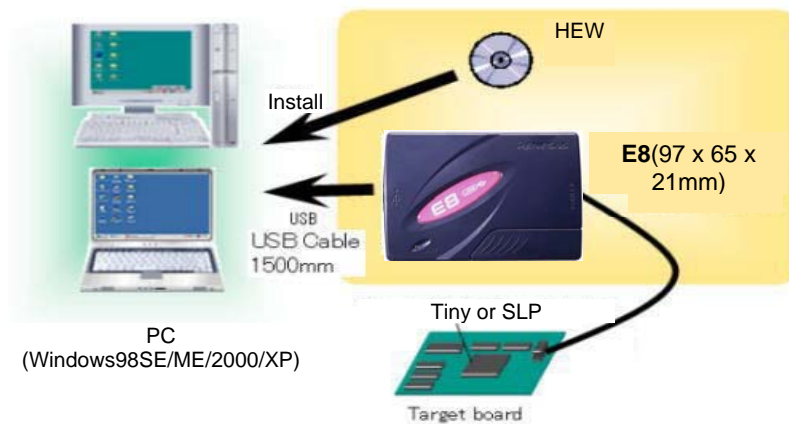

Below picture shows the platform debugging with host PC and Renesas E8 debugger. **Please note that, in debugging mode, do not mount “K1” (Relay) onto the board and also do not short Pin 3 and Pin 4 of “K1” on the board, because if Pin 3 and Pin 4 of “K1” shorted, system 5V is floating on 220V AC, which will damage E8 debugger and host PC.**

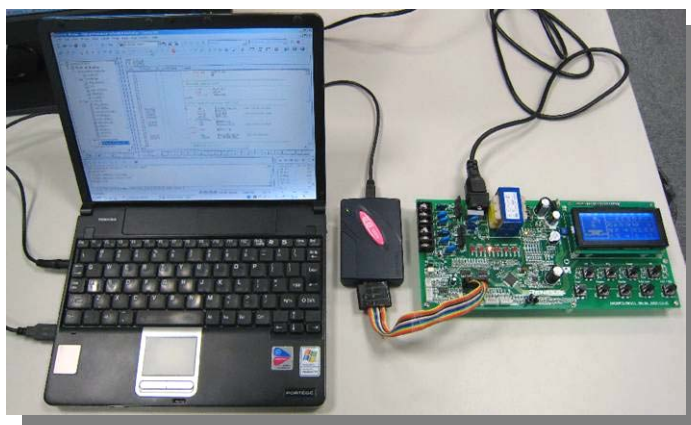

## 5.2 Test AC output with loading

For testing and evaluating AC driving and washer output function, user needs to connect the AC part on the platform with AC loading.

Firstly user need to mount “K1” onto the board or short Pin 3 and Pin 4 of “K1” for connecting AC power to the output part; then please connect the washing motor and / or system valves (Inlet or Drain) with “CN11” and “CN12”.

**Please keep in mind that, while AC power is connected to output part, platform system 5V is floating on 220V AC; therefore, user must take much care of AC power danger when testing the platform. It’s highly recommended that user take special security process for testing the AC output functions.**

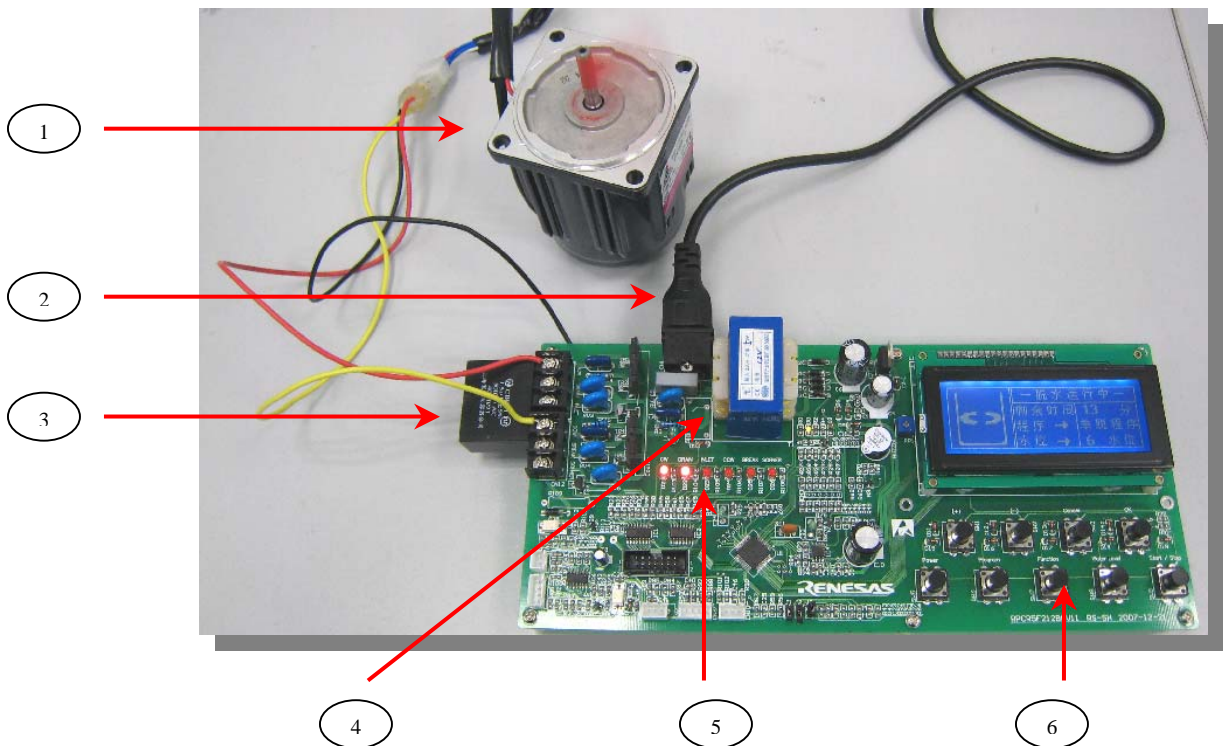

### Notes:

- 1, AC motor for demo (220V, 90r/min—1250r/min, 15W, 0.16A);
- 2, AC power input (220V, 50Hz /60Hz);

- 3, AC motor starting capacitor (CBB61, 1.5uF, 500V AC);
- 4, Relay for control AC power of output part, the designator is “K1” on the board;
- 5, AC output simulation LEDs, the function is identical with AC output;
- 6, Key array for setting the platform;

### 5.3 Test unexpected power down recovery function

For testing the unexpected power down recovery function of the platform, the platform reset circuit need to be reworked. It's recommend to use RC reset circuit instead of the platform implemented circuit because there is a power drop (nearly 1v) between “+5V” and Reset “high” Level, which make Vdet0, Vdet1 and Vdet2 cannot work normally.

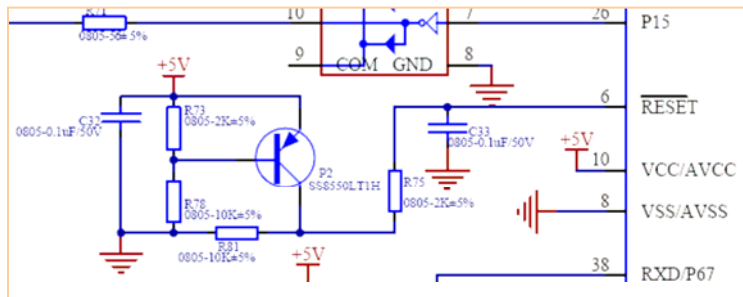

1, Platform reset circuit

Below figure shows the RC reset circuit connection, the recommended RC value is 30K-100K resistor and 104 capacitor. **Please rework the reset circuit with below RC reset circuit.**

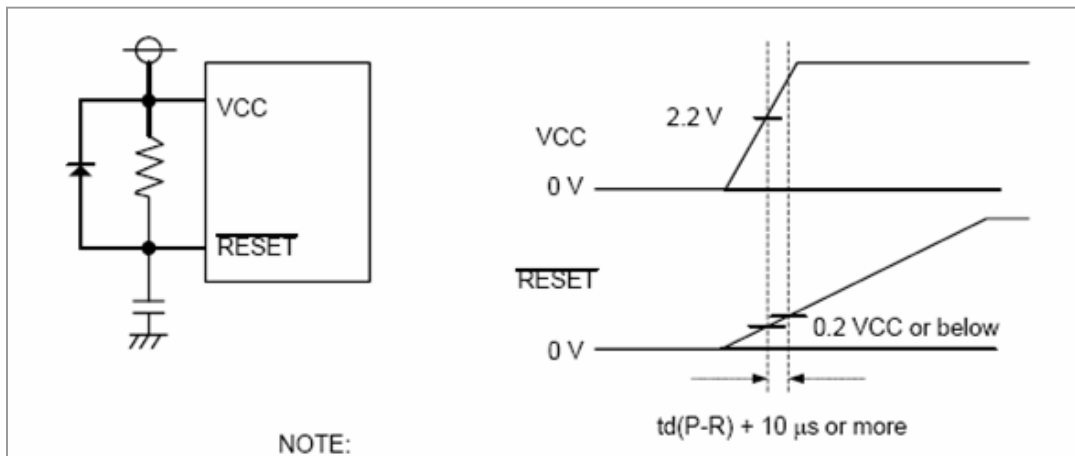

2, RC reset circuit

## Appendix:

Below are the platform washing program time tables.

Standard Program				Program		Memo Program				Program	
Low	Middle	High	Texture	Water Level	Program	Low	Middle	High	Texture	Water Level	Program
●	●	●	●	--	Inlet	●	●	●	●	--	Inlet
●	●	●	●		Soak	●	●	●	●		Soak
●	●	●	●		Wash	●	●	●	●		Wash
●	●	●	●	30"	Balance wash	●	●	●	●	30"	Balance wash
●	●	●	●	--	Drain	●	●	●	●	--	Drain
●	●	●	●	30"	Intermittent Spin	●	●	●	●	30"	Intermittent Spin
●	●	●	●	15"	Spin	●	●	●	●	1.5'	Spin
●	●	●	●	25"	Inertial Spray Spin	●	●	●	●	30"	Inertial Spin
●	●	●	●	15"	Spin	●	●	●	●	5"	Brake
●	●	●	●	25"	Inertial Spray Spin	●	●	●	●	--	Inlet
●	●	●	●	15"	Spin	●	●	●	●	3'	Wash
●	●	●	●	30"	Inertial Spin	●	●	●	●	30"	Balance wash
●	●	●	●	5"	Brake	●	●	●	●	--	Drain
●	●	●	●	--	Inlet	●	●	●	●	30"	Intermittent Spin
●	●	●	●	2"	Wash	●	●	●	●	1.5'	Spin
●	●	●	●	30"	Balance wash	●	●	●	●	30"	Inertial Spin
●	●	●	●	--	Drain	●	●	●	●	5"	Brake
●	●	●	●	30"	Intermittent Spin	●	●	●	●	--	Inlet
●	●	●	●	3'	Spin	●	●	●	●	3'	Wash
●	●	●	●	30"	Inertial Spin	●	●	●	●	30"	Balance wash
●	●	●	●	5"	Brake	●	●	●	●	--	Drain
●	●	●	●			●	●	●	●	30"	Intermittent Spin
●	●	●	●			●	●	●	●	5'	Spin
●	●	●	●			●	●	●	●	30"	Inertial Spin
●	●	●	●			●	●	●	●	5"	Brake



Wool		Program	
●	--	Inlet	
●	10'	Soak	
●	5'	Wash	
●	30"	Balance wash	Rinse1
●	--	Drain	
●	60"	Intermittent Spin	
●	60"	Spin	
●	30"	Inertial Spin	
●	5"	Brake	
●	--	Inlet	
●	2'	Wash	
●	30"	Balance wash	
●	--	Drain	
●	60"	Intermittent Spin	Rinse2
●	60"	Spin	
●	30"	Inertial Spin	
●	5"	Brake	
●	--	Inlet	
●	2'	Wash	Spin
●	30"	Balance wash	
●	--	Drain	
●	60"	Intermittent Spin	
●	2'	Spin	
●	30"	Inertial Spin	
●	5"	Brake	

4. Wool program

Strong		Program	
●	--	Inlet	
●	40'	Soak	
●	20'	Wash	
●	30"	Balance wash	Rinse
●	--	Drain	
●	60"	Intermittent Spin	
●	60"	Spin	
●	30"	Inertial Spin	
●	5"	Brake	
●	--	Inlet	
●	5'	Wash	
●	--	Drain	
●	60"	Intermittent Spin	
●	60"	Spin	Spin
●	30"	Inertial Spin	
●	5"	Brake	
●	--	Inlet	
●	5'	Wash	
●	--	Drain	Spin
●	60"	Intermittent Spin	
●	5'	Spin	
●	30"	Inertial Spin	
●	5"	Brake	

3. Strong program

Soft	Program		
● --	Inlet	Soak, Wash	
● 20'	Soak		
● 10'	Wash		
● 30"	Balance wash	Rinse1	
● --	Drain		
● 60"	Intermittent Spin		
● 60"	Spin		
● 30"	Inertial Spin		
● 5"	Brake		
● --	Inlet		
● 3'	Wash		
● 30"	Balance wash		
● --	Drain		Rinse2
● 60"	Intermittent Spin		
● 60"	Spin		
● 30"	Inertial Spin		
● 5"	Brake		
● --	Inlet		
● 3'	Wash		
● 30"	Balance wash		
● --	Drain	Rinse3	
● 60"	Intermittent Spin		
● 60"	Spin		
● 30"	Inertial Spin		
● 5"	Brake		
● --	Inlet		
● 3'	Wash		
● 30"	Balance wash		
● --	Drain		Spin
● 60"	Intermittent Spin		
● 3'	Spin		
● 3"	Inertial Spin		
● 5"	Brake		

6. Soft program

Child	Program		
● --	Inlet	Soak, Wash	
● 20'	Soak		
● 10'	Wash		
● 30"	Balance wash	Rinse1	
● --	Drain		
● 60"	Intermittent Spin		
● 60"	Spin		
● 30"	Inertial Spin		
● 5"	Brake		
● --	Inlet		
● 3'	Wash		
● 30"	Balance wash		
● --	Drain		Rinse2
● 60"	Intermittent Spin		
● 60"	Spin		
● 30"	Inertial Spin		
● 5"	Brake		
● --	Inlet		
● 3'	Wash		
● 30"	Balance wash		
● --	Drain	Rinse3	
● 60"	Intermittent Spin		
● 60"	Spin		
● 30"	Inertial Spin		
● 5"	Brake		
● --	Inlet		
● 3'	Wash		
● 30"	Balance wash		
● --	Drain		Spin
● 60"	Intermittent Spin		
● 3'	Spin		
● 30"	Inertial Spin		
● 5"	Brake		

5. Child program



Speedy		Program	
●	water level 3	Inlet	Soak, Wash
●	2'	Wash	
●	--	Drain	Rinse
●	20"	Intermittent Spin	
●	30"	Spin	
●	10"	Inertial Spin	
●	5"	Brake	
●	water level 3	Inlet	
●	1'	Wash	
●	--	Drain	Spin
●	20"	Intermittent Spin	
●	1'	Spin	
●	15"	Inertial Spin	
●	5"	Brake	

8. Speedy program

Silk		Program	
●	--	Inlet	Soak, Wash
●	300"	Wash	
●	--	Drain	Rinse
●	60"	Intermittent Spin	
●	60"	Spin	
●	30"	Inertial Spin	
●	5'	Brake	
●	--	Inlet	
●	120"	Wash	
●	--	Drain	
●	60"	Intermittent Spin	
●	60"	Spin	
●	30"	Inertial Spin	
●	5"	Brake	
●	--	Inlet	
●	120"	Wash	
●	--	Drain	Spin
●	60"	Intermittent Spin	
●	120"	Spin	
●	30"	Inertial Spin	
●	5"	Brake	

7. Silk program

●	--	Inlet	Wash
●	600"	Wash	
●	30"	Balance wash	

9. Wash

●	--	Drain	Rinse
●	60"	Intermittent Spin	
●	60"	Spin	
●	30"	Inertial Spin	
●	5"	Brake	
●	--	Inlet	
●	180"	Wash	
●	30"	Balance wash	

10. Rinse program

●	--	Drain	Spin
●	60"	Intermittent Spin	
●	180"	Spin	
●	30"	Inertial Spin	
●	5"	Brake	

11. Spin program

### Notes regarding these materials

1. This document is provided for reference purposes only so that Renesas customers may select the appropriate Renesas products for their use. Renesas neither makes warranties or representations with respect to the accuracy or completeness of the information contained in this document nor grants any license to any intellectual property rights or any other rights of Renesas or any third party with respect to the information in this document.
2. Renesas shall have no liability for damages or infringement of any intellectual property or other rights arising out of the use of any information in this document, including, but not limited to, product data, diagrams, charts, programs, algorithms, and application circuit examples.
3. You should not use the products or the technology described in this document for the purpose of military applications such as the development of weapons of mass destruction or for the purpose of any other military use. When exporting the products or technology described herein, you should follow the applicable export control laws and regulations, and procedures required by such laws and regulations.
4. All information included in this document such as product data, diagrams, charts, programs, algorithms, and application circuit examples, is current as of the date this document is issued. Such information, however, is subject to change without any prior notice. Before purchasing or using any Renesas products listed in this document, please confirm the latest product information with a Renesas sales office. Also, please pay regular and careful attention to additional and different information to be disclosed by Renesas such as that disclosed through our website. (<http://www.renesas.com>)
5. Renesas has used reasonable care in compiling the information included in this document, but Renesas assumes no liability whatsoever for any damages incurred as a result of errors or omissions in the information included in this document.
6. When using or otherwise relying on the information in this document, you should evaluate the information in light of the total system before deciding about the applicability of such information to the intended application. Renesas makes no representations, warranties or guaranties regarding the suitability of its products for any particular application and specifically disclaims any liability arising out of the application and use of the information in this document or Renesas products.
7. With the exception of products specified by Renesas as suitable for automobile applications, Renesas products are not designed, manufactured or tested for applications or otherwise in systems the failure or malfunction of which may cause a direct threat to human life or create a risk of human injury or which require especially high quality and reliability such as safety systems, or equipment or systems for transportation and traffic, healthcare, combustion control, aerospace and aeronautics, nuclear power, or undersea communication transmission. If you are considering the use of our products for such purposes, please contact a Renesas sales office beforehand. Renesas shall have no liability for damages arising out of the uses set forth above.
8. Notwithstanding the preceding paragraph, you should not use Renesas products for the purposes listed below:
  - (1) artificial life support devices or systems
  - (2) surgical implantations
  - (3) healthcare intervention (e.g., excision, administration of medication, etc.)
  - (4) any other purposes that pose a direct threat to human lifeRenesas shall have no liability for damages arising out of the uses set forth in the above and purchasers who elect to use Renesas products in any of the foregoing applications shall indemnify and hold harmless Renesas Technology Corp., its affiliated companies and their officers, directors, and employees against any and all damages arising out of such applications.
9. You should use the products described herein within the range specified by Renesas, especially with respect to the maximum rating, operating supply voltage range, movement power voltage range, heat radiation characteristics, installation and other product characteristics. Renesas shall have no liability for malfunctions or damages arising out of the use of Renesas products beyond such specified ranges.
10. Although Renesas endeavors to improve the quality and reliability of its products, IC products have specific characteristics such as the occurrence of failure at a certain rate and malfunctions under certain use conditions. Please be sure to implement safety measures to guard against the possibility of physical injury, and injury or damage caused by fire in the event of the failure of a Renesas product, such as safety design for hardware and software including but not limited to redundancy, fire control and malfunction prevention, appropriate treatment for aging degradation or any other applicable measures. Among others, since the evaluation of microcomputer software alone is very difficult, please evaluate the safety of the final products or system manufactured by you.
11. In case Renesas products listed in this document are detached from the products to which the Renesas products are attached or affixed, the risk of accident such as swallowing by infants and small children is very high. You should implement safety measures so that Renesas products may not be easily detached from your products. Renesas shall have no liability for damages arising out of such detachment.
12. This document may not be reproduced or duplicated, in any form, in whole or in part, without prior written approval from Renesas.
13. Please contact a Renesas sales office if you have any questions regarding the information contained in this document, Renesas semiconductor products, or if you have any other inquiries.

© 2008. Renesas Technology Corp., All rights reserved.