

概要

R8C/36T-A 触摸按键解决方案旨在提供一个低成本高集成的单芯片解决方案，该触摸按键解决方案非常适合于带触摸功能的柜式空调或其他高端家电触摸按键的应用。

目标芯片

R8C/36T-A

目录

1. 硬件平台	2
2. 开发环境.....	3
3. 系统控制框图.....	5
4. 触摸原理介绍.....	6
5. 原理图描述.....	9
6. PCB 设计规则.....	11
7. 软件描述.....	12
8. 网页与支持.....	15

1. 硬件平台

R8C36T-A 触摸按键评估板是针对于带触摸按键功能的柜式空调器而设计，它支持多达28路触摸按键，59个输入输出，支持多达128K的ROM空间和10K的RAM空间。12路12位AD转换，1路DTC,4路定时器和3路UART。

评估板有以下特点：

- ⌚ 9 路触摸按键和1路滑条。
- ⌚ 1 路定时器输出用于蜂鸣器。
- ⌚ 2 路AD转换用于温度传感器。
- ⌚ 1 路IIC通信用于EEPROM。
- ⌚ 1 路定时器用于红外线输入信号检测。
- ⌚ 7 段双八显示及LED显示。
- ⌚ 步进电机及负载控制
- ⌚ 支持E1在线仿真
- ⌚ 按键复位电路
- ⌚ 两毫米亚克力板

LED
显示



图 1.1 空调触摸按键评估板

2. 开发环境

2.1 High-performance Embedded Workshop

High-performance Embedded Workshop 是一个强大的集成开发环境，它主要用于RENESAS微控制器的嵌入式开发，主要特点如下：

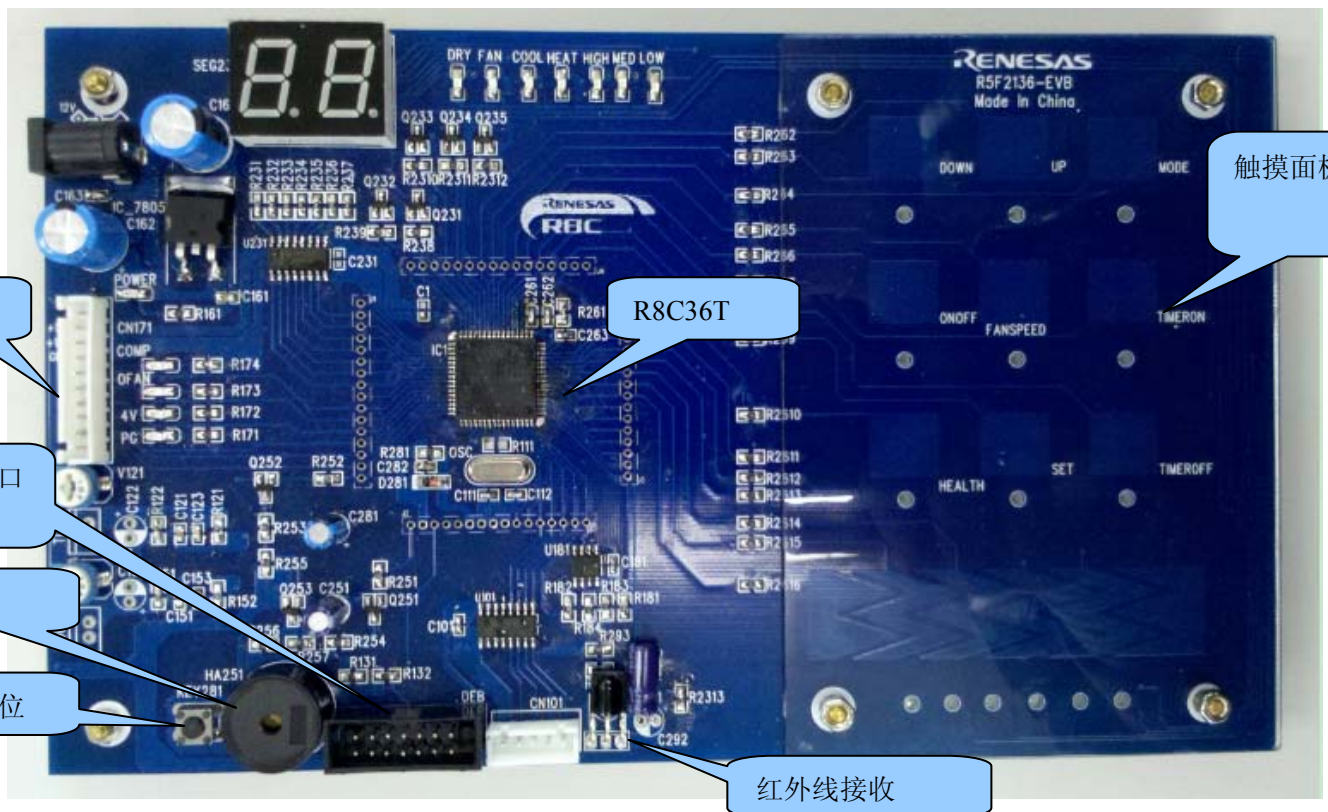
- 用户通过可视化界面可以灵活配置编译器、汇编器和链接器的各个选项。
- 集成了文本编辑器，可以提供客户化的着色功能从而提高代码的可靠性。
- 可配置的开发环境，允许用于内嵌个性化工具。
- 集成调试器，用户可以在一个应用程序内编译及调试工程。
- 版本控制及支持。



图 2.1: HEW 开发环境

2.2 E1

E1 是用于连接目标板和电脑的仿真器，采用 14Pin 端子，USB 供电。

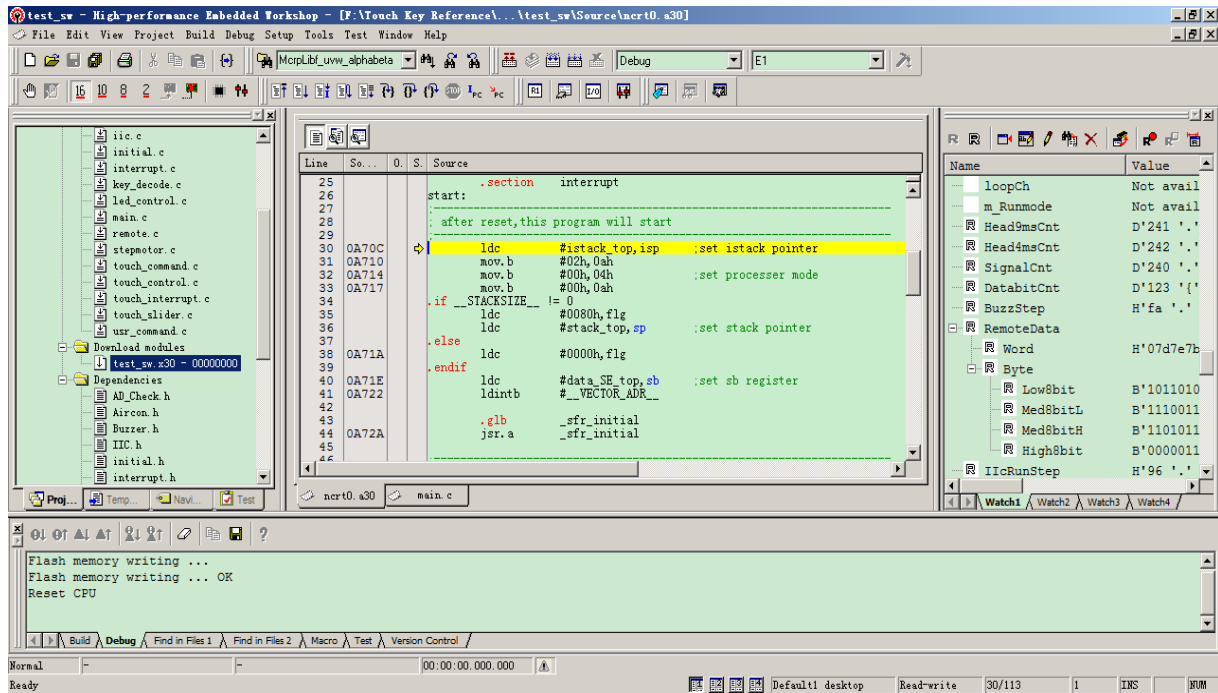
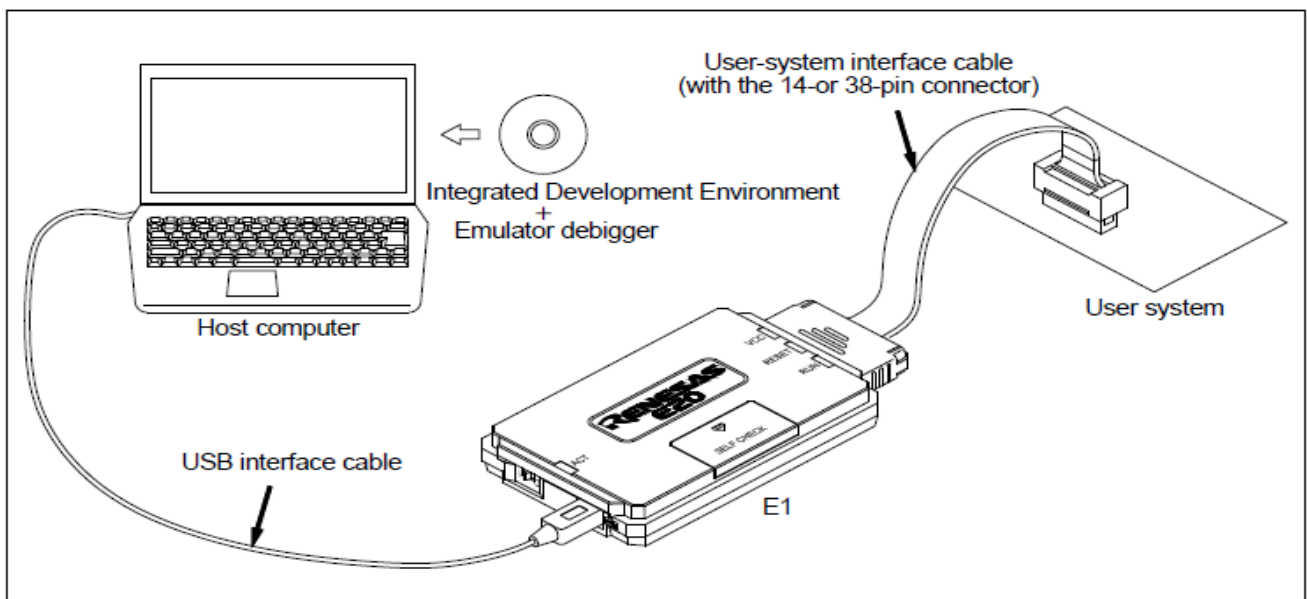

2.3 Workbench4

触摸按键微控制器R8C36T-A通过传感器控制单元(SCU)感知人体在电极上形成的分布电容,从而达到响应触摸按键的效果。而Renesas Workbench通过目标板和High-performance Embedded Workshop(HEW)的连接,能提供一套可靠地可视化界面进行实时监测,可动态显示各个通道的测量值、参考值及阈值,给用户调试带来极大地便利。



图 2.2: Workbench 用户界面



测量值：传感监测单元 SCU 的测量数据。

阈值：进行传感开关判断的阀值。

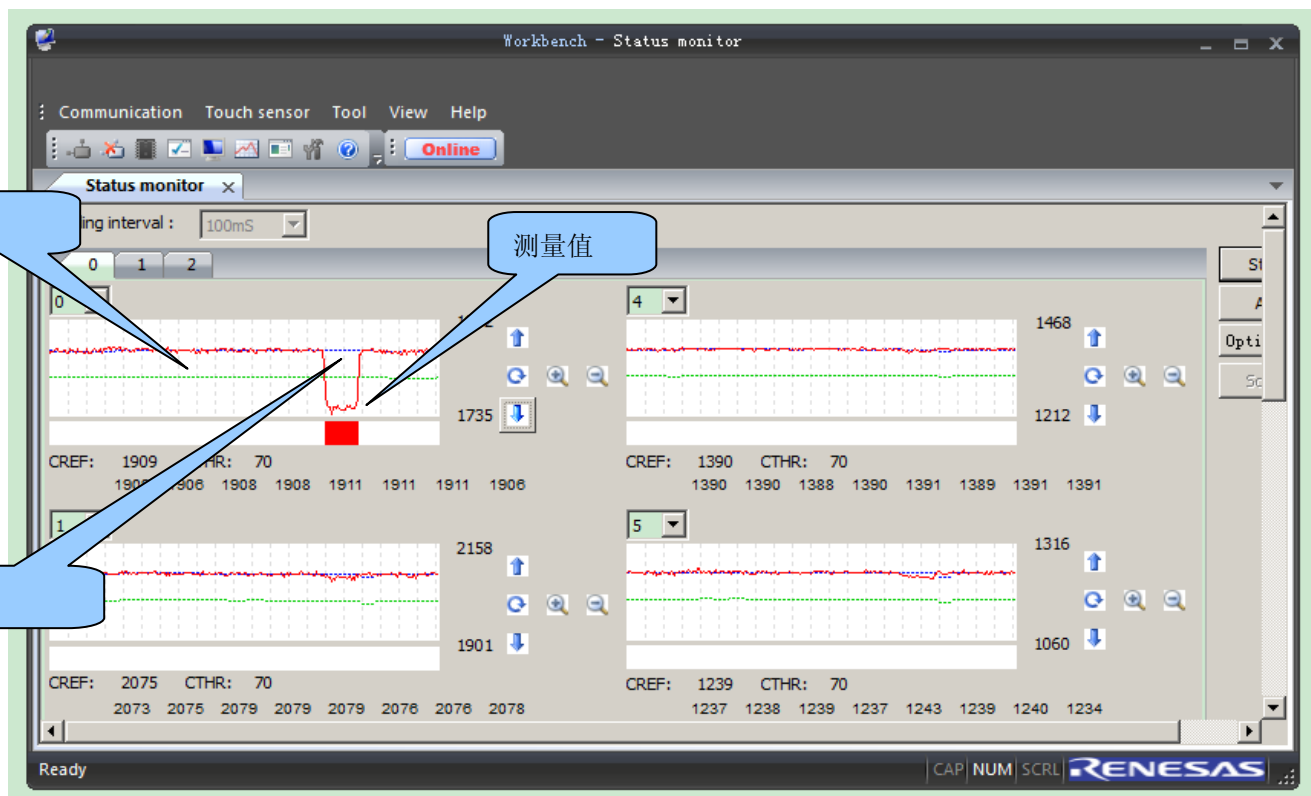
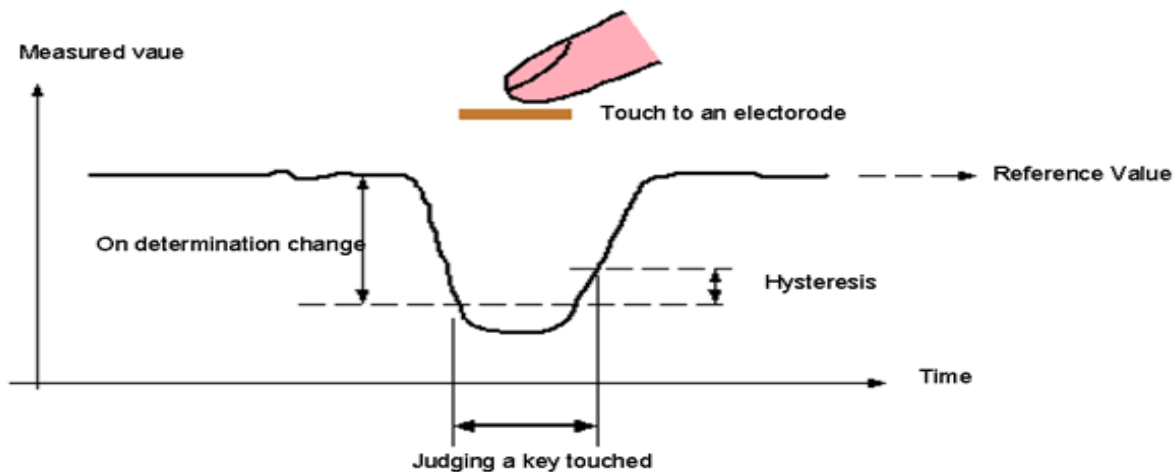
参考值：测量值的平均值，一般取 128 次平均。

3. 系统控制框图

评估板由 R8C36T-A MCU 部分及触摸面板部分组成，系统框图显示了整个空调控制器的控制系统，R8C36T-A 的资源配置非常适合带触摸功能的空调柜机使用。用户可以通过 E1 仿真器连接到目标板，通过 HEW 进行代码编辑及调试，通过 Workbench 观测和调试触摸按键的效果。



图 3.1: 空调控制系统框图



图 3.2: 触摸按键开发环境框图

4. 触摸按键原理

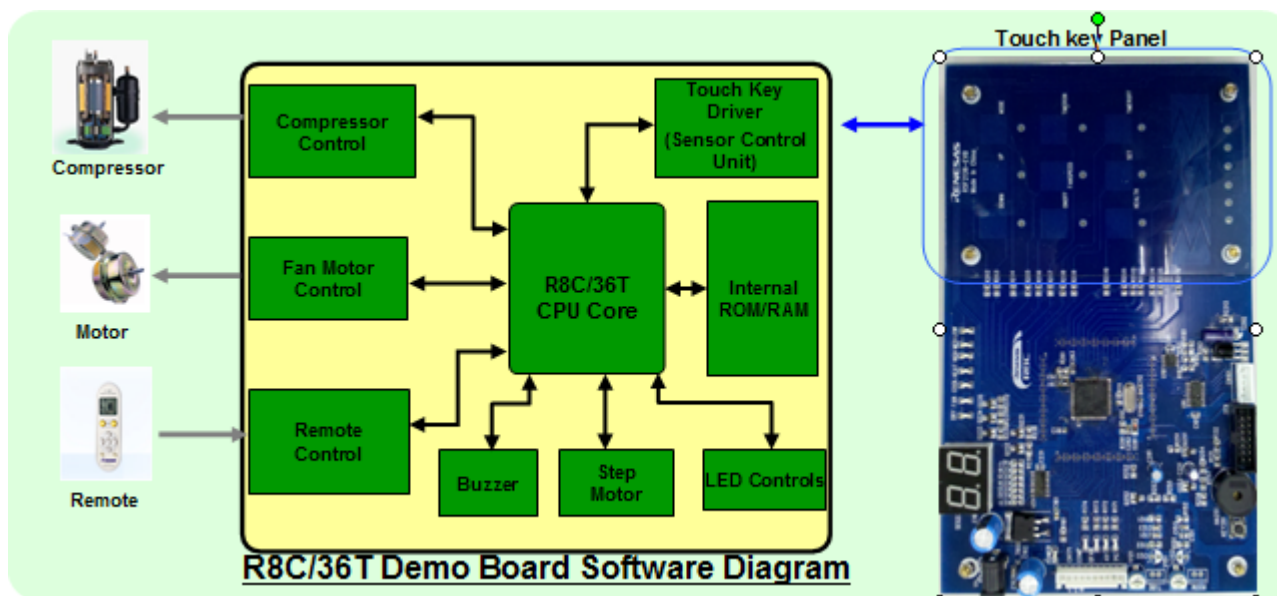
4.1 概要

触摸传感器芯片 R8C/36T-A 通过检测连接在触摸终端上的电极的分布电容值的变化, 来判断触摸按键的开关。如图 4.1, 在电极与地之间存在着分布电容。因为人体本身也是导体, 当人的手指接近电极, 在手指和电极之间就会产生一个分布电容。从而整个电极到地的电容值也产生了变化, 通过检测分布电容值的变化, 可以进行触摸与否的判定。



图 4.1 电极分布电容图

4.2 检测电路

触摸按键侦测电路如图4.2所示，

Cr: 分压电容(几pF到几十pF之间)

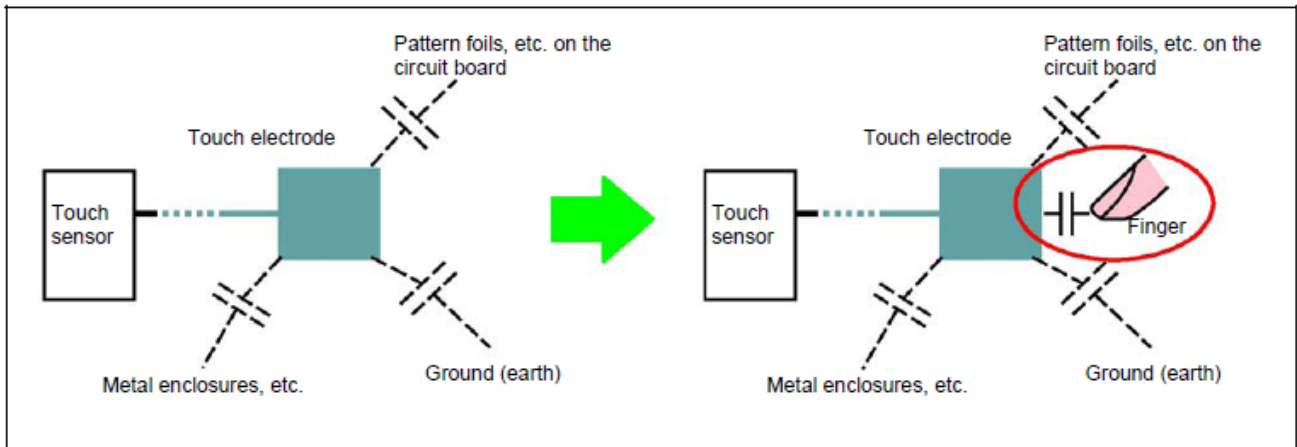
Rc: 充电放电电阻(几kΩ到几十kΩ之间)

Cc: 充电放电电容(大约0.1 μF)

电容和电阻的精度并没有明确规定，然而，高的偏移值可能导致每个独立的产品都需要进行校正，因此，推荐使用高精度的器件(电阻，精度5%或以上，电容，精度10%或以上)。

Cx: 电极的分布电容

Cx值大概在几pF到几十pF之间

而Cx的变化量大约在几pF或者更低。



图 4.2 触摸测量电路

4.3 电极分布电容值的测量方法

触摸电极分布电容值通过Cc放电时测量管脚CHxA的电压值获得，测量步骤如下：

- (1) 通过管脚CHxC 施加VCC对Cc电容进行充电。
- (2) 当对Cc充电完成后，通过把CHxA和CHxB连接到地对Cc进行放电操作
- (3) 在对Cc电容进行短时间的放电后，保持管脚CHxA, CHxB和CHxC高阻状态 (Hi-Z), 然后测试CHxA引脚的电压. 此时,如图4.3所示, 把CHxA管脚检测的电压标记为Va , 把管脚CHxC上的电压标记为Vc, 则, Va电压的表达式如下图所示：

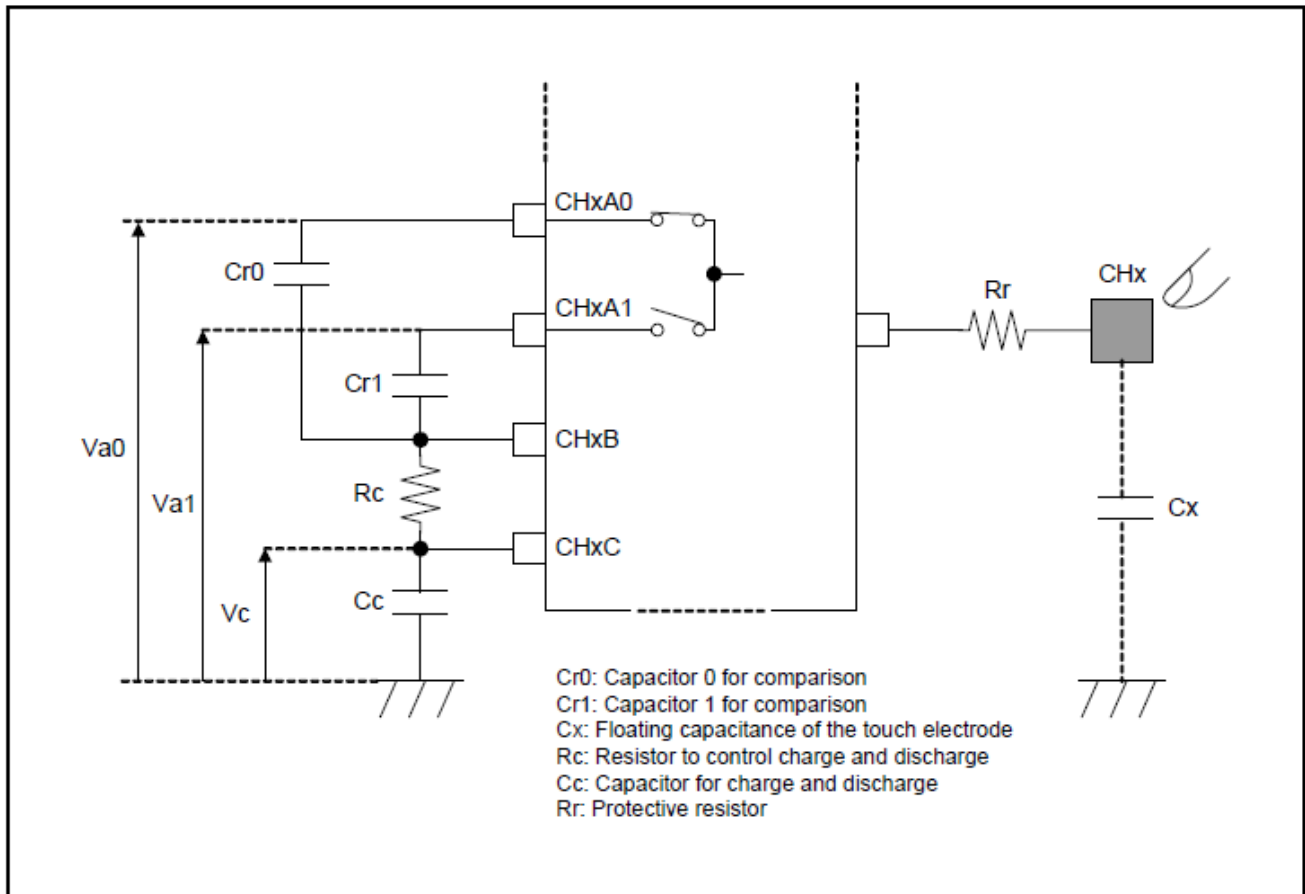
$$V_a = \frac{C_r}{C_r + C_x} V_c$$

Va和Vc随时间变化如图5.3所示。

- (4)重复第(2)步和第(3)步
- (5)通过VLT0特殊功能寄存器设定管脚CHxA的阈值电平(input threshold value control register 0).
通过主计数器累计放电的次数直到Va下降到管脚的阈值电平以下（0.35VCC/0.5VCC/0.7VCC可选），此时，次计数器开始递减计数，主计数器继续累计放电次数直到次计数值的默认值递减为0，
- (6)主计数器上的计数值就是所需要的电极分布电容值。



图 4.3 Va 和 Vc 随时间变化如图

5.原理图描述

5.1 原理图

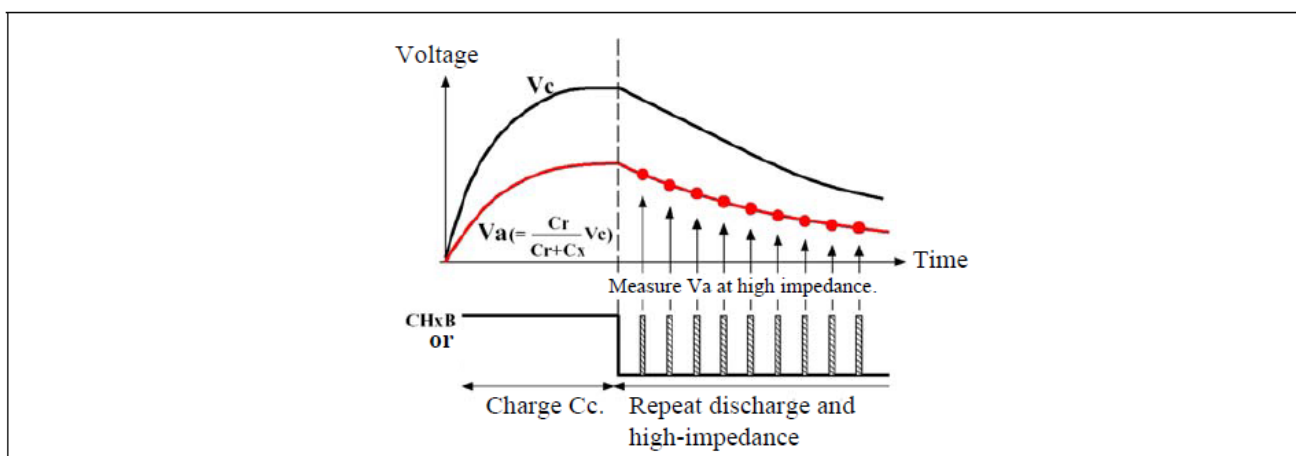

图 5.1 空调触摸按键原理图

5.2 PCB



图 5.2 PCB 顶层丝印层

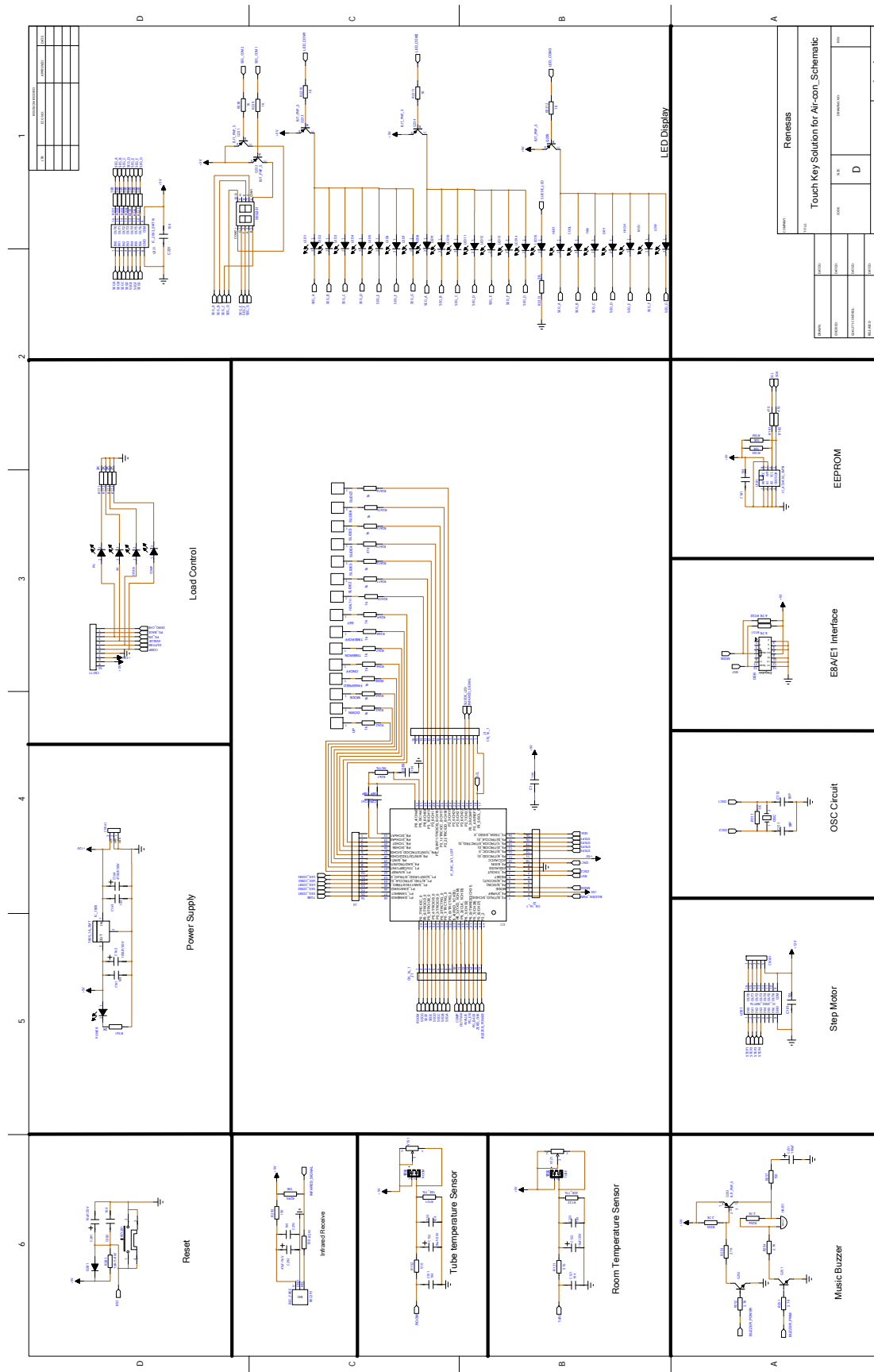

图 5.3 PCB 底层丝印层

6. PCB 设计规则

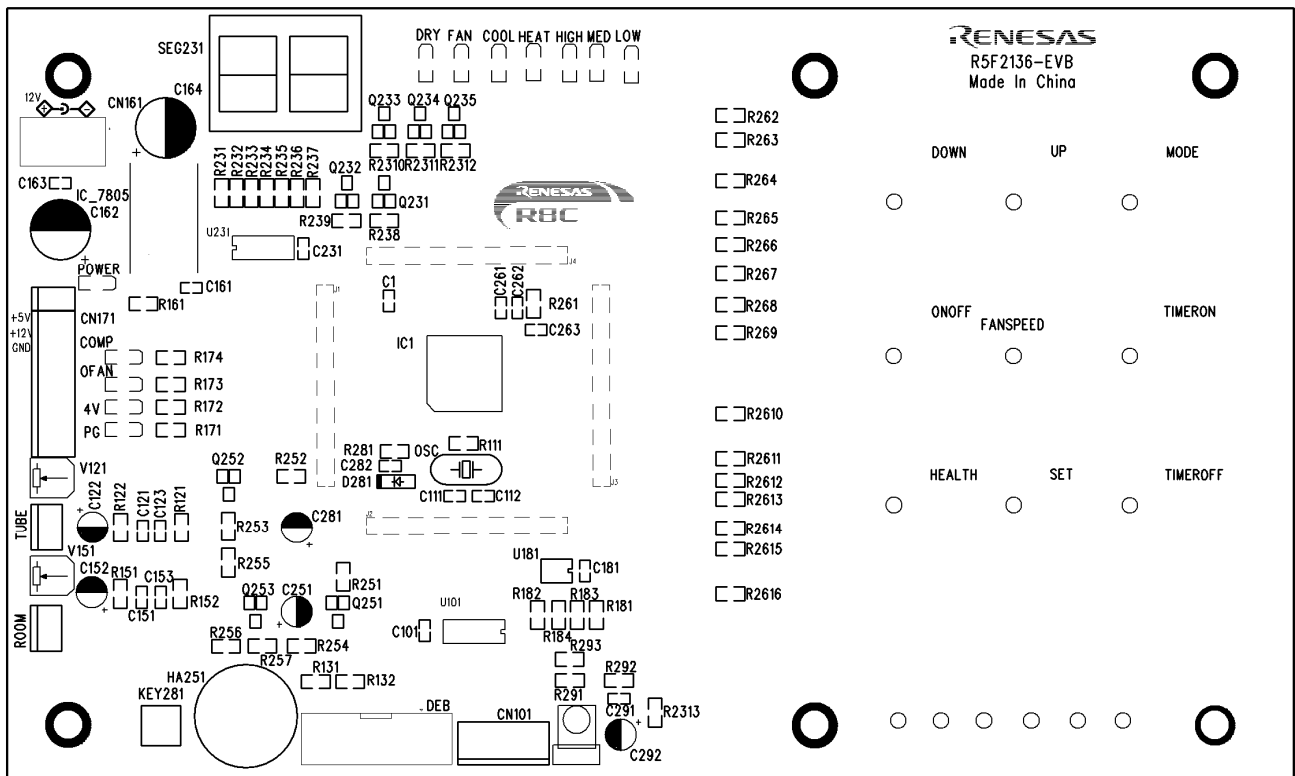
(1) 布线图

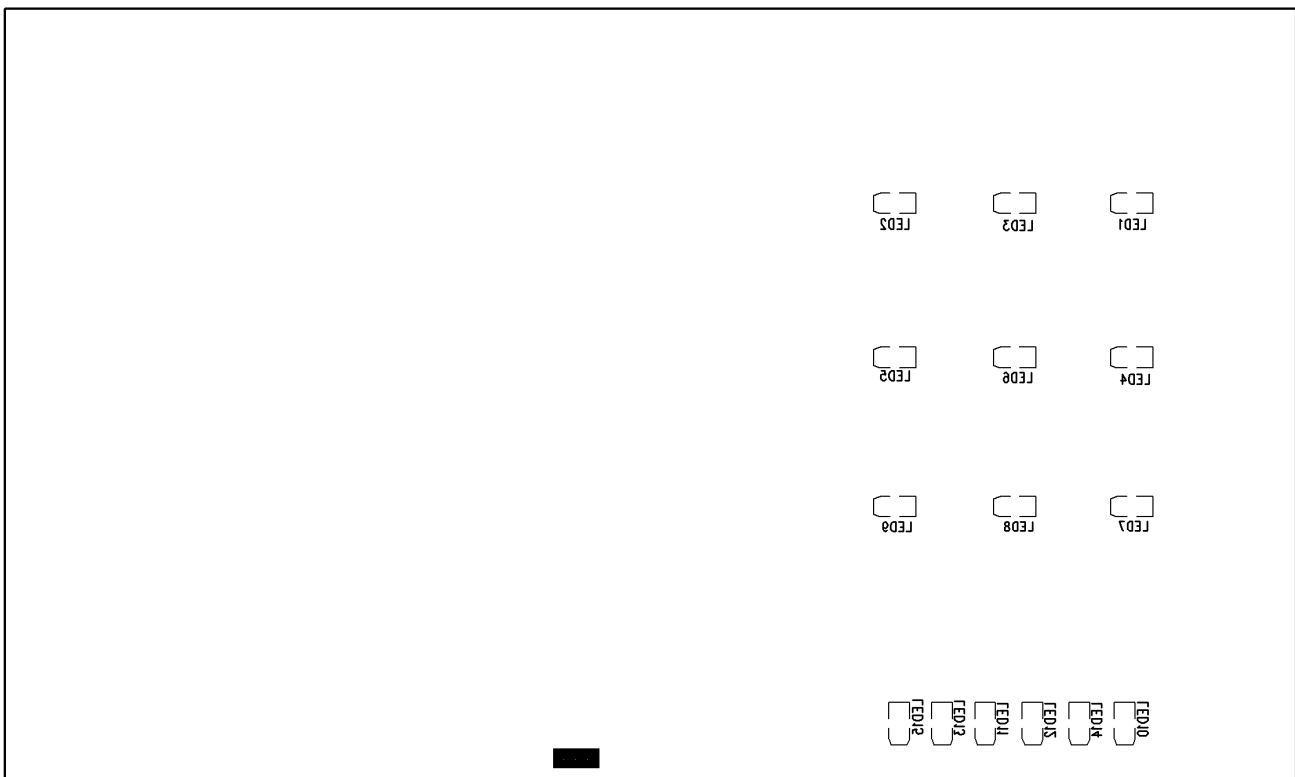
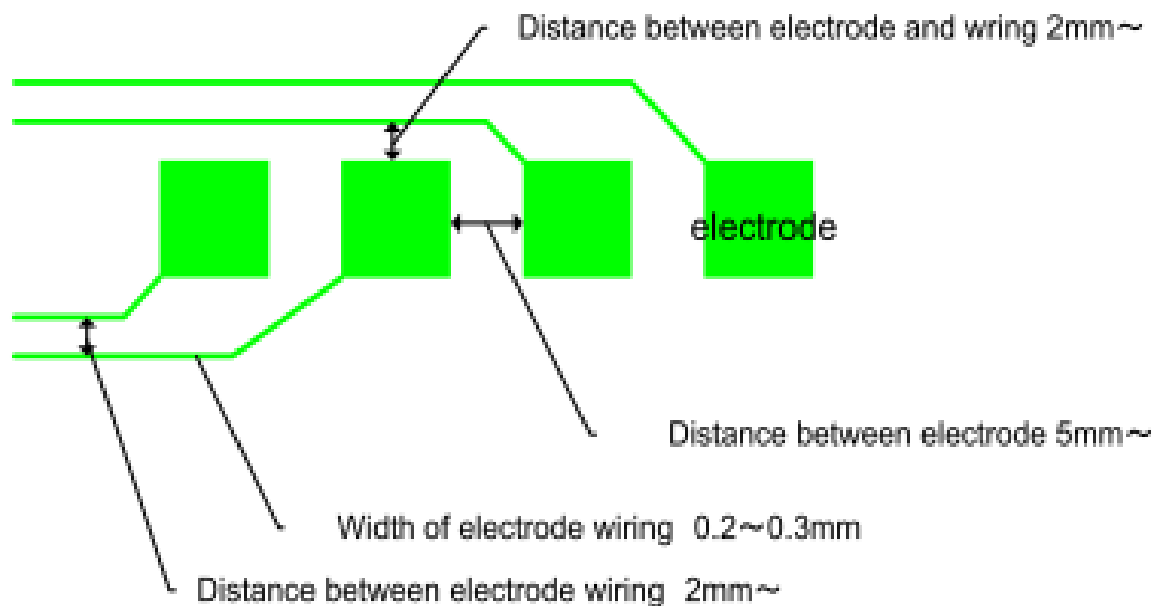

- (2) 电极导线宽度 : 0.2-0.3mm.
- (3) 电极与导线、导线与导线距离: 大于 2 mm 。
- (4) 电极导线长度: 少于 18 cm。
- (5) 电极间距离: 大于 5 mm。
- (6) 电极大小: 10x10 mm 到 15x15 mm; 不要太大, 形状推荐方形和圆形。
- (7) 电极材质: 没有特殊限制, 电阻(R_r) 如使用高阻材料则需要调整。
- (8) 铺地处理: 电极以及电极导线周围不能铺地。推荐在 Cr, Cc, Rc 和 MCU 背面进行铺地处理。

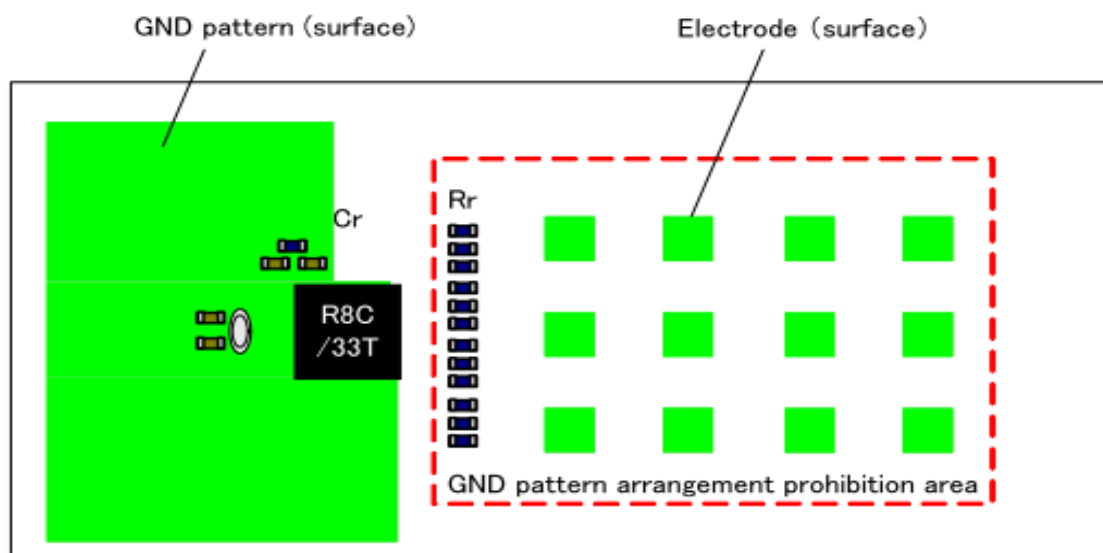

Figure 6.1 触摸按键铺地规则

7. 软件概述

7.1 软件系统框图



图 7.1 软件系统框图

7.2 软件流程图

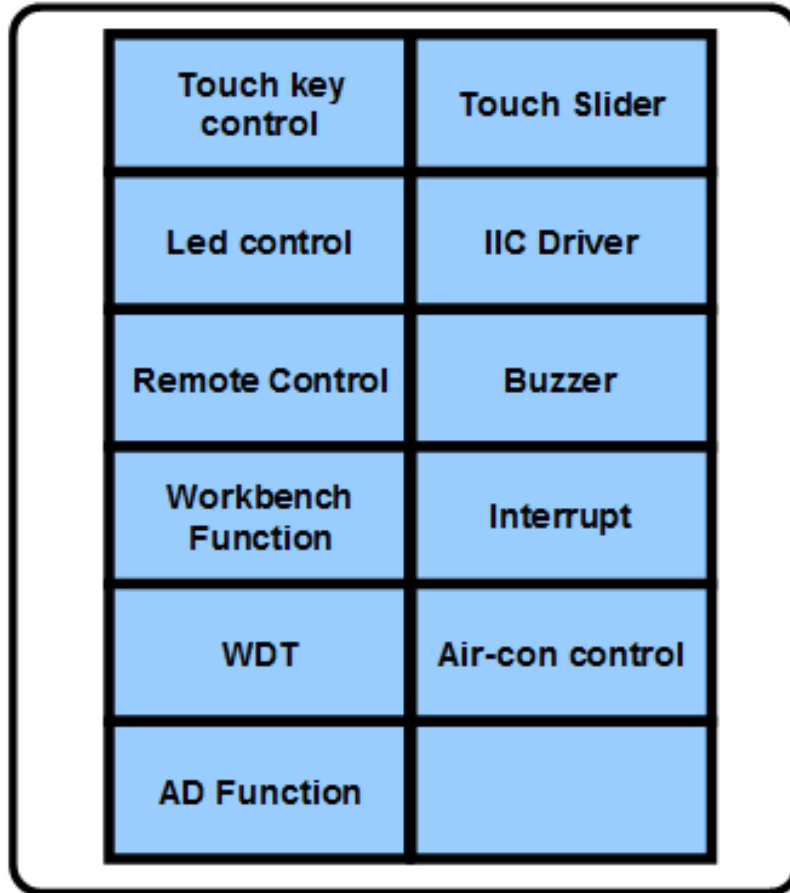

图 7.2 触摸按键方案软件流程图

7.3 触摸按键软件检测方式

7.3.1 触摸按键检测流程图

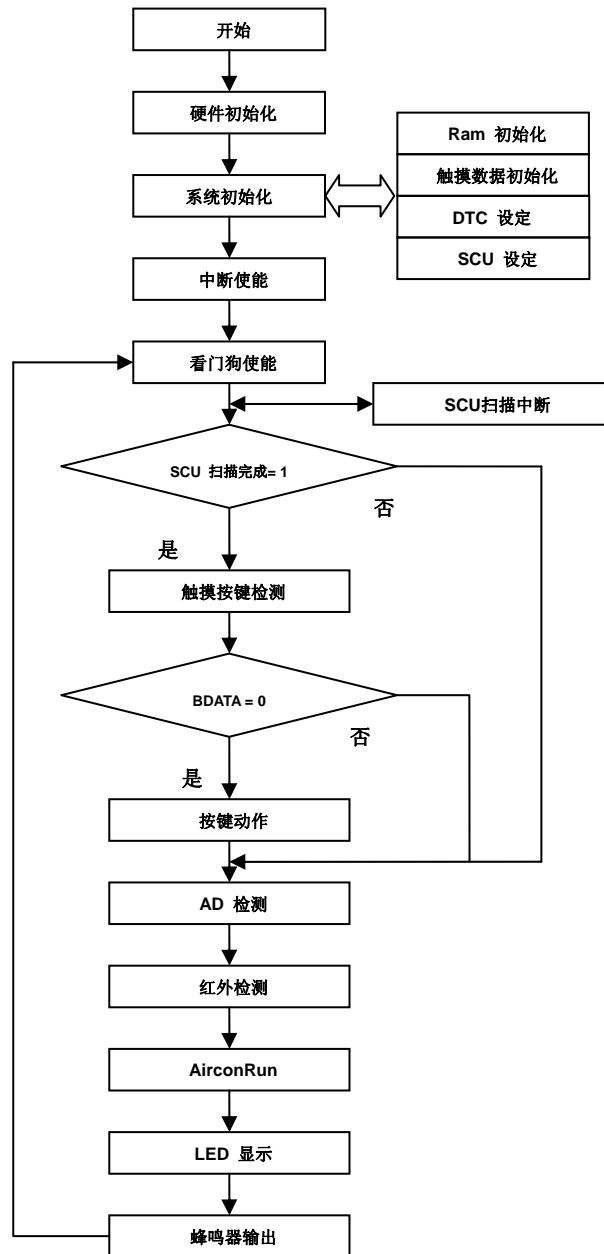

图 7.3 触摸按键检测流程图

7.3.2 触摸按键检测流程

FT_Add_M_Ave(): 该子程序用于计算 Ncount 值;

Make_Cthr(): 该子程序用于计算阈值提供给 onoff judgement 子程序进行开关的判断;

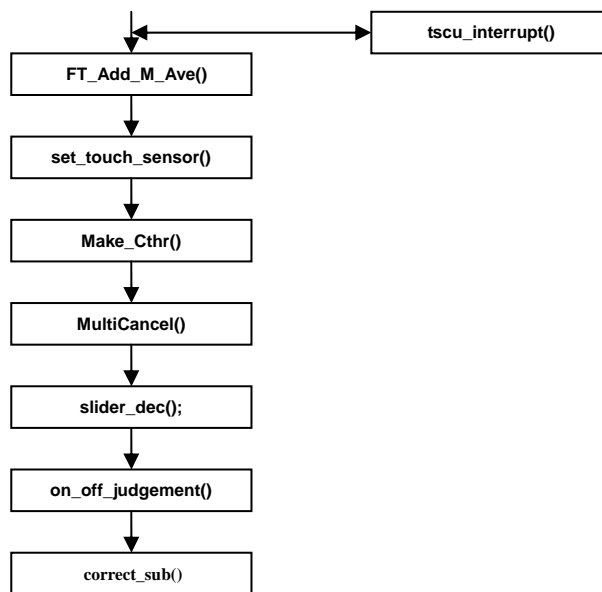
MultiCancel(): 该子程序用于禁止同一时刻多路按键使能 ;

Slider_dec(): 该子程序用于检测滑条动作;

on_off_judgement(): 该子程序用于判断触摸按键开关;

correct_sub(): 该子程序用于计算参考值;

7.3.3 触摸按键参数和变量

BDATA: 该变量用于存储触摸按键最终开关值;

Ncount: SCU 监测器的检测值;

Dcount: Ncount 值与 Nref 值之差;

Nref[Ch]: Ncount 的参考值 , 是测量值的平均值;

Nhys[Ch]: 触摸按键开关判断的回差值;

Nthr[Ch]: 开关判断的阈值;

Msa: 按键长按时间;

Mode: 检测模式, 值在 4~10 之间;

Acd: 按键去抖次数;

Dci: 校准测量值次数;

Athr: 多按键处理时的阈值;

网页与支持

瑞萨电子主页

<http://www.renesas.com/>

咨询

<http://www.renesas.com/inquiry>

参考文档

R8C/36T-A Group Hardware User's Manual: r01uh0240ej0100_r8c36t-a

Touch Sensor IC Principle of Detection and Adjustment of the External Circuit: rej05b1344_r8cap

Workbench user manual: Workbench4_manual_eng_Rev1.00_.internal_release.pdf

Revision Record

Rev.	Date	Description	
		Page	Summary
0.01	May 26, 2012	—	First edition issued

General Precautions in the Handling of MPU/MCU Products

The following usage notes are applicable to all MPU/MCU products from Renesas. For detailed usage notes on the products covered by this manual, refer to the relevant sections of the manual. If the descriptions under General Precautions in the Handling of MPU/MCU Products and in the body of the manual differ from each other, the description in the body of the manual takes precedence.

1. Handling of Unused Pins

Handle unused pins in accord with the directions given under Handling of Unused Pins in the manual.

- The input pins of CMOS products are generally in the high-impedance state. In operation with an unused pin in the open-circuit state, extra electromagnetic noise is induced in the vicinity of LSI, an associated shoot-through current flows internally, and malfunctions occur due to the false recognition of the pin state as an input signal become possible. Unused pins should be handled as described under Handling of Unused Pins in the manual.

2. Processing at Power-on

The state of the product is undefined at the moment when power is supplied.

- The states of internal circuits in the LSI are indeterminate and the states of register settings and pins are undefined at the moment when power is supplied.

In a finished product where the reset signal is applied to the external reset pin, the states of pins are not guaranteed from the moment when power is supplied until the reset process is completed.

In a similar way, the states of pins in a product that is reset by an on-chip power-on reset function are not guaranteed from the moment when power is supplied until the power reaches the level at which resetting has been specified.

3. Prohibition of Access to Reserved Addresses

Access to reserved addresses is prohibited.

- The reserved addresses are provided for the possible future expansion of functions. Do not access these addresses; the correct operation of LSI is not guaranteed if they are accessed.

4. Clock Signals

After applying a reset, only release the reset line after the operating clock signal has become stable.

When switching the clock signal during program execution, wait until the target clock signal has stabilized.

- When the clock signal is generated with an external resonator (or from an external oscillator) during a reset, ensure that the reset line is only released after full stabilization of the clock signal. Moreover, when switching to a clock signal produced with an external resonator (or by an external oscillator) while program execution is in progress, wait until the target clock signal is stable.

5. Differences between Products

Before changing from one product to another, i.e. to one with a different type number, confirm that the change will not lead to problems.

- The characteristics of MPU/MCU in the same group but having different type numbers may differ because of the differences in internal memory capacity and layout pattern. When changing to products of different type numbers, implement a system-evaluation test for each of the products.

Notice

- All information included in this document is current as of the date this document is issued. Such information, however, is subject to change without any prior notice. Before purchasing or using any Renesas Electronics products listed herein, please confirm the latest product information with a Renesas Electronics sales office. Also, please pay regular and careful attention to additional and different information to be disclosed by Renesas Electronics such as that disclosed through our website.
- Renesas Electronics does not assume any liability for infringement of patents, copyrights, or other intellectual property rights of third parties by or arising from the use of Renesas Electronics products or technical information described in this document. No license, express, implied or otherwise, is granted hereby under any patents, copyrights or other intellectual property rights of Renesas Electronics or others.
- You should not alter, modify, copy, or otherwise misappropriate any Renesas Electronics product, whether in whole or in part.
- Descriptions of circuits, software and other related information in this document are provided only to illustrate the operation of semiconductor products and application examples. You are fully responsible for the incorporation of these circuits, software, and information in the design of your equipment. Renesas Electronics assumes no responsibility for any losses incurred by you or third parties arising from the use of these circuits, software, or information.
- When exporting the products or technology described in this document, you should comply with the applicable export control laws and regulations and follow the procedures required by such laws and regulations. You should not use Renesas Electronics products or the technology described in this document for any purpose relating to military applications or use by the military, including but not limited to the development of weapons of mass destruction. Renesas Electronics products and technology may not be used for or incorporated into any products or systems whose manufacture, use, or sale is prohibited under any applicable domestic or foreign laws or regulations.
- Renesas Electronics has used reasonable care in preparing the information included in this document, but Renesas Electronics does not warrant that such information is error free. Renesas Electronics assumes no liability whatsoever for any damages incurred by you resulting from errors in or omissions from the information included herein.
- Renesas Electronics products are classified according to the following three quality grades: "Standard", "High Quality", and "Specific". The recommended applications for each Renesas Electronics product depends on the product's quality grade, as indicated below. You must check the quality grade of each Renesas Electronics product before using it in a particular application. You may not use any Renesas Electronics product for any application categorized as "Specific" without the prior written consent of Renesas Electronics. Further, you may not use any Renesas Electronics product for any application for which it is not intended without the prior written consent of Renesas Electronics. Renesas Electronics shall not be in any way liable for any damages or losses incurred by you or third parties arising from the use of any Renesas Electronics product for an application categorized as "Specific" or for which the product is not intended where you have failed to obtain the prior written consent of Renesas Electronics. The quality grade of each Renesas Electronics product is "Standard" unless otherwise expressly specified in a Renesas Electronics data sheets or data books, etc.
"Standard": Computers; office equipment; communications equipment; test and measurement equipment; audio and visual equipment; home electronic appliances; machine tools; personal electronic equipment, and industrial robots.
"High Quality": Transportation equipment (automobiles, trains, ships, etc.); traffic control systems; anti-disaster systems; anti-crime systems; safety equipment; and medical equipment not specifically designed for life support.
"Specific": Aircraft; aerospace equipment; submersible repeaters; nuclear reactor control systems; medical equipment or systems for life support (e.g. artificial life support devices or systems), surgical implantations, or healthcare intervention (e.g. excision, etc.), and any other applications or purposes that pose a direct threat to human life.
- You should use the Renesas Electronics products described in this document within the range specified by Renesas Electronics, especially with respect to the maximum rating, operating supply voltage range, movement power voltage range, heat radiation characteristics, installation and other product characteristics. Renesas Electronics shall have no liability for malfunctions or damages arising out of the use of Renesas Electronics products beyond such specified ranges.
- Although Renesas Electronics endeavors to improve the quality and reliability of its products, semiconductor products have specific characteristics such as the occurrence of failure at a certain rate and malfunctions under certain use conditions. Further, Renesas Electronics products are not subject to radiation resistance design. Please be sure to implement safety measures to guard them against the possibility of physical injury, and injury or damage caused by fire in the event of the failure of a Renesas Electronics product, such as safety design for hardware and software including but not limited to redundancy, fire control and malfunction prevention, appropriate treatment for aging degradation or any other appropriate measures. Because the evaluation of microcomputer software alone is very difficult, please evaluate the safety of the final products or system manufactured by you.
- Please contact a Renesas Electronics sales office for details as to environmental matters such as the environmental compatibility of each Renesas Electronics product. Please use Renesas Electronics products in compliance with all applicable laws and regulations that regulate the inclusion or use of controlled substances, including without limitation, the EU RoHS Directive. Renesas Electronics assumes no liability for damages or losses occurring as a result of your noncompliance with applicable laws and regulations.
- This document may not be reproduced or duplicated, in any form, in whole or in part, without prior written consent of Renesas Electronics.
- Please contact a Renesas Electronics sales office if you have any questions regarding the information contained in this document or Renesas Electronics products, or if you have any other inquiries.
(Note 1) "Renesas Electronics" as used in this document means Renesas Electronics Corporation and also includes its majority-owned subsidiaries.
(Note 2) "Renesas Electronics product(s)" means any product developed or manufactured by or for Renesas Electronics.



SALES OFFICES

Renesas Electronics Corporation

<http://www.renesas.com>

Refer to "<http://www.renesas.com/>" for the latest and detailed information.

Renesas Electronics America Inc.
2880 Scott Boulevard Santa Clara, CA 95050-2554, U.S.A.
Tel: +1-408-588-6000, Fax: +1-408-588-6130

Renesas Electronics Canada Limited
1101 Nicholson Road, Newmarket, Ontario L3Y 9C3, Canada
Tel: +1-905-898-5441, Fax: +1-905-898-3220

Renesas Electronics Europe Limited
Dukes Meadow, Millboard Road, Bourne End, Buckinghamshire, SL8 5FH, U.K
Tel: +44-1628-585-100, Fax: +44-1628-585-900

Renesas Electronics Europe GmbH
Arcadiastrasse 10, 40472 Düsseldorf, Germany
Tel: +49-211-65030, Fax: +49-211-6503-1327

Renesas Electronics (China) Co., Ltd.
7th Floor, Quantum Plaza, No.27 ZhiChunLu Haidian District, Beijing 100083, P.R.China
Tel: +86-10-8235-1155, Fax: +86-10-8235-7679

Renesas Electronics (Shanghai) Co., Ltd.
Unit 204, 205, AZIA Center, No.1233 Lujiazui Ring Rd., Pudong District, Shanghai 200120, China
Tel: +86-21-5877-1818, Fax: +86-21-6887-7858 / -7898

Renesas Electronics Hong Kong Limited
Unit 1601-1613, 16/F., Tower 2, Grand Century Place, 193 Prince Edward Road West, Mongkok, Kowloon, Hong Kong
Tel: +852-2886-9318, Fax: +852 2886-9022/9044

Renesas Electronics Taiwan Co., Ltd.
13F, No. 363, Fu Shing North Road, Taipei, Taiwan
Tel: +886-2-8175-9600, Fax: +886 2-8175-9670

Renesas Electronics Singapore Pte. Ltd.
1 harbourFront Avenue, #06-10, Keppel Bay Tower, Singapore 098632
Tel: +65-6213-0200, Fax: +65-6278-8001

Renesas Electronics Malaysia Sdn.Bhd.
Unit 906, Block B, Menara Amcorp, Amcorp Trade Centre, No. 18, Jln Persiaran Barat, 46050 Petaling Jaya, Selangor Darul Ehsan, Malaysia
Tel: +60-3-7955-9390, Fax: +60-3-7955-9510

Renesas Electronics Korea Co., Ltd.
11F., Samik Lavied' or Bldg., 720-2 Yeoksam-Dong, Kangnam-Ku, Seoul 135-080, Korea
Tel: +82-2-558-3737, Fax: +82-2-558-5141