

R2A20114AFP/ASP

Continuous Conduction Mode Interleaving PFC Control IC

R03DS0051EJ0100

Rev.1.00

Aug 29, 2011

Description

R2A20114AFP/ASP is a boost converter control IC with PFC (Power Factor Correction). Employing continuous conduction mode interleaving PFC, it performs higher efficiency and lower switching noise even for high power use. Interleaving control of the boost converters, namely, producing 180 degrees phase shift between the output signals (GD1,2) driving the boost converters, enables the system to perform high conversion efficiency and low switching noises and, at the same time, to reduce ripple currents in input and output current and then this allows use of smaller components such as boost inductors, input filters and output capacitors.

R2A20114AFP/ASP integrates a various kinds of protection circuits, such as the detection circuit of breaking of wire in feedback loop, two modes of over voltage protection circuits, over current protection circuit and error output circuit (*¹), which improve the reliability of the power supply system and reduce the number of component parts on the system.

Features

- Maximum Ratings
 - Supply voltage Vcc: 24 V
 - Operating junction temperature Tjopr: from -40 to +150 degrees centigrade
- Electrical characteristics
 - VFB feedback voltage VREF: 2.5 V ± 1.5%
 - UVLO (Undervoltage Lockout) operation start voltage VH: 10.4 V ± 0.7 V
 - UVLO operation shutdown voltage VL: 8.9 V ± 0.5 V
 - UVLO hysteresis voltage Hysvvl : 1.5 V ± 0.5 V
- Functions
 - Boost converter control with continuous conduction mode
 - Interleaving control
 - Frequency modulation (*²)
 - Brownout
 - Phase drop (*¹)
 - External clock synchronization input
 - External clock synchronization output (*¹)
 - Two modes of over voltage protections
 - Mode 1: Dynamic OVP preventing over voltage after sudden variation of load.
 - Mode 2: Static OVP preventing over voltage in the period of normal operation.
 - Feedback loop wire breaking/open detector
 - Dual over voltage protection circuits (*¹): FB and OVP2 terminals
 - Current balance control
 - Phase 1 and Phase 2 independent over current protection
 - Package line-up
 - Pb-free LQFP-40 (R2A20114AFP)
 - Pb-free SOP-20 (R2A20114ASP)

Notes: *1 Supported only by R2A20114AFP

*2 Frequency modulation periods (dfm) of R2A20114ASP are fixed.

The Function List of R2A20114AFP/ASP

Item		R2A20114ASP	R2A20114AFP
PFC control		Continuous conduction mode interleaving	
Current detection method		Shunt resistor	
Package		SOP-20	LQFP-40
Protection circuits	Brownout detection	Supported	Supported
	2nd OVP	Not supported	Supported
	Phase error	Not supported	Supported
Noise reduction	Jitter generation (Frequency modulation)	Supported (But, frequency modulation period (ffm)(* ¹) is fixed)	Supported
Synchronization with external signal	Input	Supported	Supported
	Output	Not supported	Supported
Efficiency improvement	Phase drop	Not supported	Supported

Note: *1 Refer to the figure depicted below:

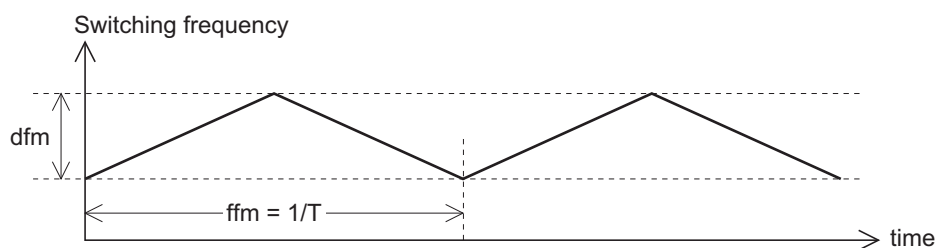

Ordering Information

Part No.	Package Name	Package Code	Package Abbreviation	Taping Abbreviation (Quantity)	Remarks
R2A20114AFPW0	FP-40EV	PLQP0040JB-C	FP	W (2000 pcs/reel)	non-HF
R2A20114AFPW5					HF
R2A20114ASPW0	FP-20DAV	PRSP0020DD-B	SP	W (2000 pcs/reel)	non-HF
R2A20114ASPW5					HF

Note: HF: Halogen-Free

Pin Arrangement of R2A20114AFP

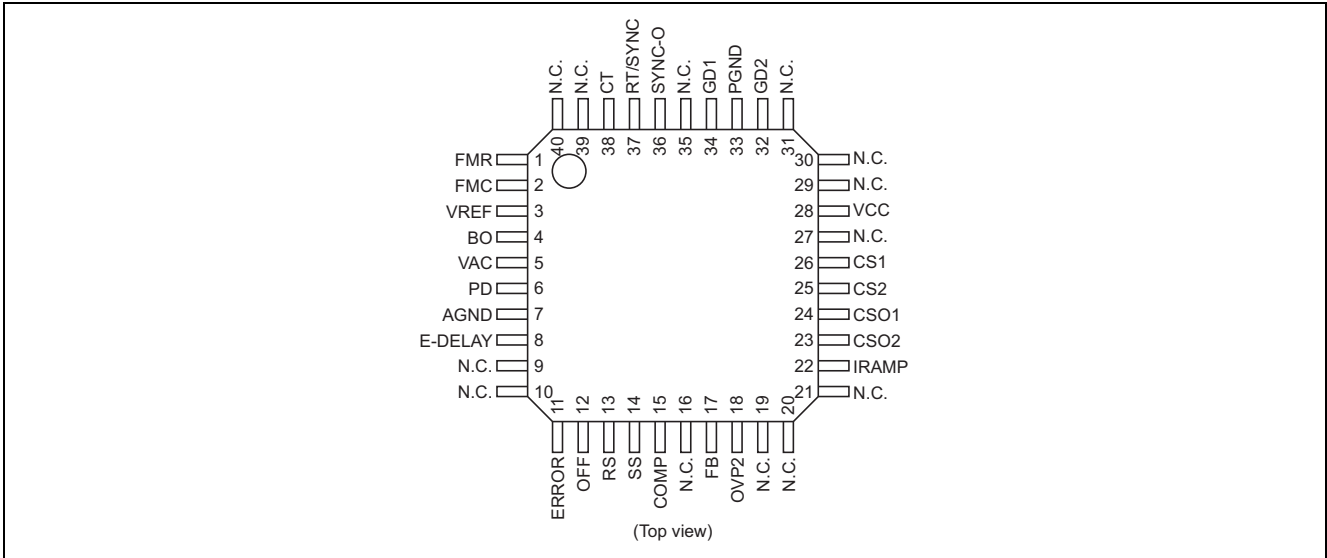

Pin Functions of R2A20114AFP

Pin No.	Pin Name	Function
1	FMR	Frequency modulation setting resistor connecting terminal
2	FMC	Frequency modulation setting capacitor connecting terminal
3	VREF	Reference voltage output terminal
4	BO	Brownout input terminal
5	VAC	AC voltage input terminal
6	PD	Phase drop input terminal
7	AGND	Analog ground
8	E-DELAY	Delay of the Error signal setting terminal
9, 10	N.C.	Open
11	ERROR	Error output terminal
12	OFF	Shutdown terminal (VCC Reset)
13	RS	Current correction setting resistor connecting terminal
14	SS	Soft start setting capacitor connecting terminal
15	COMP	Error amplifier output terminal (to be phase-compensated)
16	N.C.	Open
17	FB	Error amplifier input terminal (feedback voltage input terminal)
18	QVP2	OVP2 input terminal
19-21	N.C.	Open
22	IRAMP	Ramp waveform setting resistor connecting terminal
23	CSO2	Current sense amplifier 2 output terminal (to be phase-compensated)
24	CSO1	Current sense amplifier 1 output terminal (to be phase-compensated)
25	CS2	Current sense 2 input terminal
26	CS1	Current sense 1 input terminal
27	N.C.	Open
28	VCC	Supply voltage terminal
29-31	N.C.	Open
32	GD2	Converter 2 Power MOSFET drive terminal
33	PGND	Power ground
34	GD1	Converter 1 Power MOSFET drive terminal
35	N.C.	Open
36	SYNC-O	Synchronization signal output terminal
37	RT/SYNC	Frequency setting resistor connecting terminal / Sync. Signal input terminal
38	CT	Frequency setting capacitor connecting terminal
39, 40	N.C.	Open

Pin Arrangement of R2A20114ASP

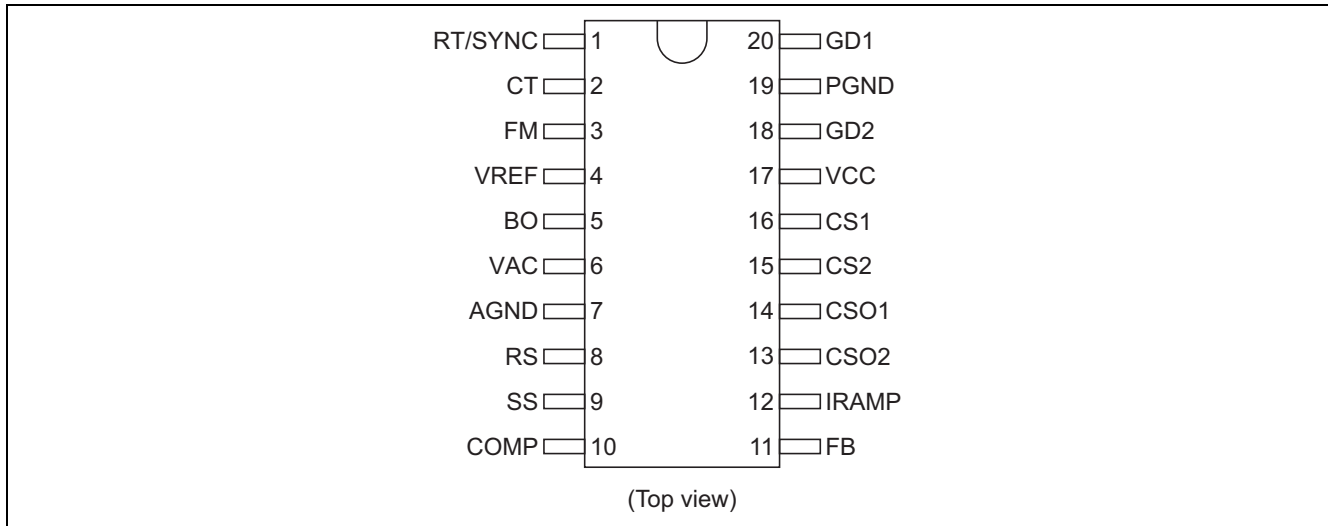

Pin Functions of R2A20114ASP

Pin No.	Pin Name	Function
1	RT/SYNC	Frequency setting timing resistor connecting terminal / Sync. signal input terminal
2	CT	Frequency setting timing capacitor connecting terminal
3	FM	Frequency modulation setting timing capacitor connecting terminal
4	VREF	Reference voltage output terminal
5	BO	Brownout input terminal
6	VAC	AC voltage input terminal
7	AGND	Analog ground
8	RS	Current correction setting resistor connecting terminal
9	SS	Soft start setting capacitor connecting terminal
10	COMP	Error amplifier output terminal (to be phase-compensated)
11	FB	Error amplifier input terminal (feedback voltage input terminal)
12	IRAMP	Ramp waveform setting resistor connecting terminal
13	CSO2	Current sense amplifier 2 output terminal (to be phase-compensated)
14	CSO1	Current sense amplifier Output 1 output terminal (to be phase-compensated)
15	CS2	Current sense 2 input terminal
16	CS1	Current sense 1 input terminal
17	VCC	Supply voltage terminal
18	GD2	Converter 2 Power MOSFET drive terminal
19	PGND	Power ground
20	GD1	Converter 1 Power MOSFET drive terminal

Block Diagram of R2A20114AFP

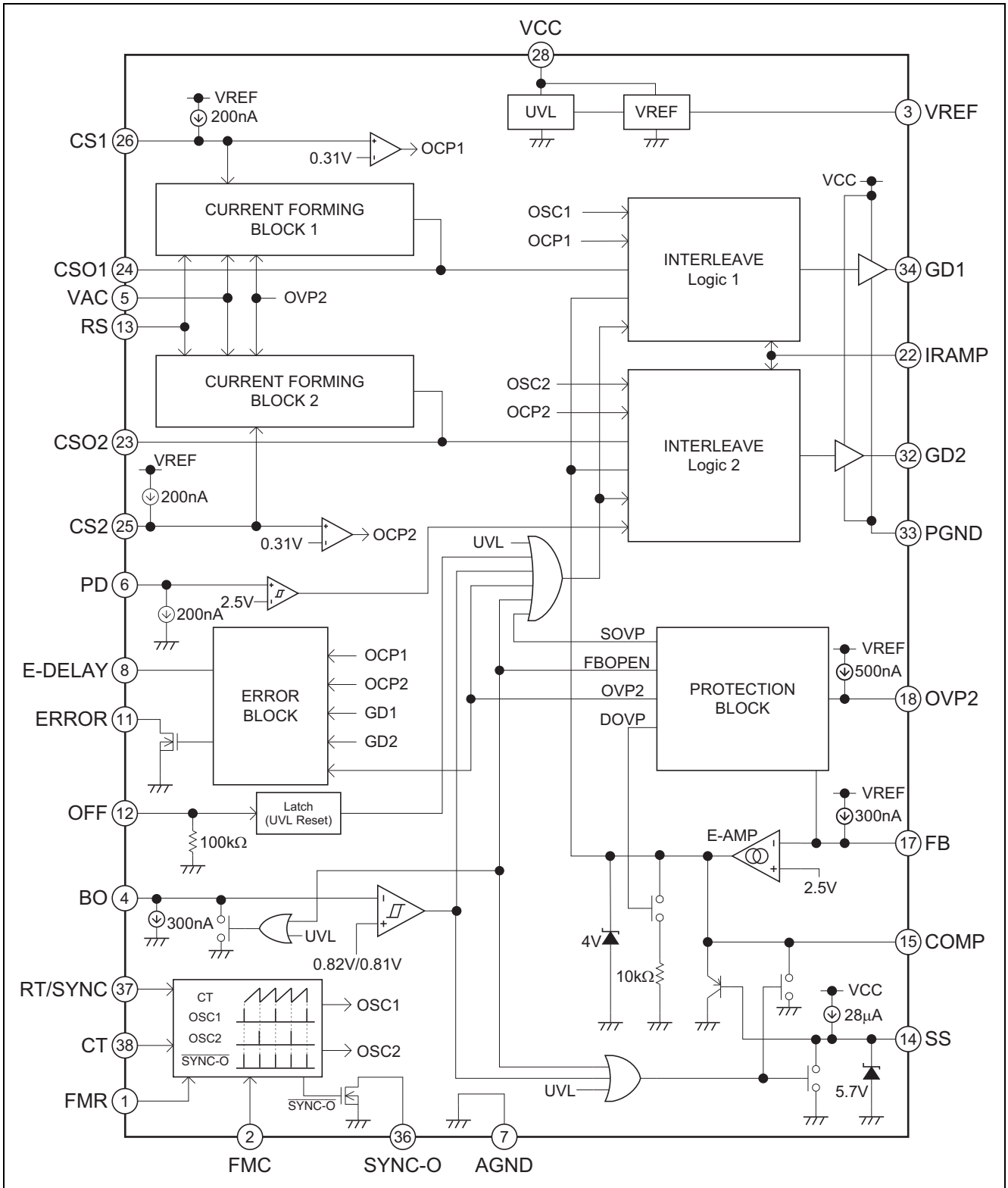

Block Diagram of R2A20114ASP

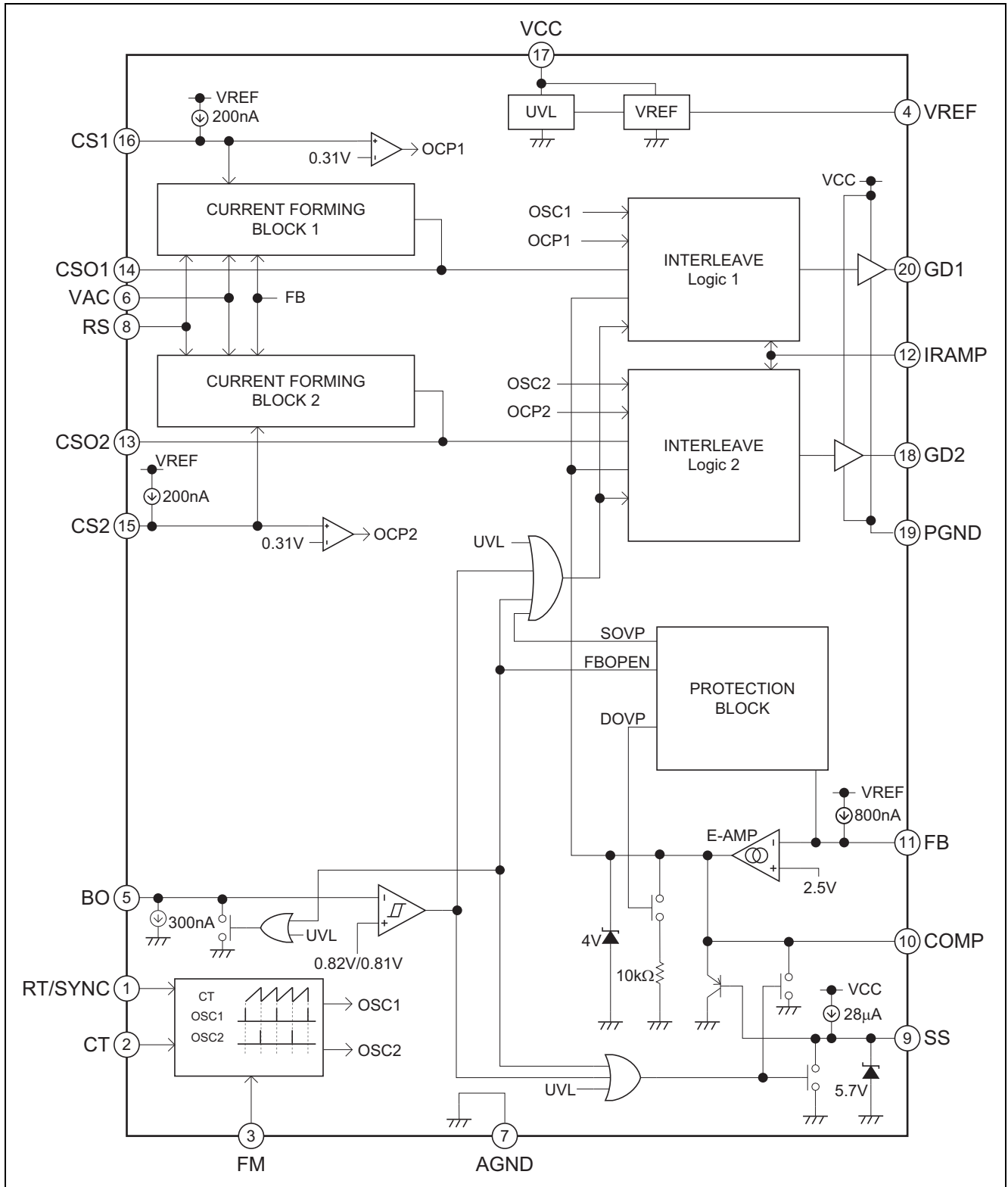

Absolute Maximum Ratings

Item	Symbol	Value	Unit	Note	
Supply voltage	VCC	-0.3 to +24	V	3	
GD1 and 2	Peak current	l _{pk-gd1} , l _{pk-gd2}	±1	A	3, 4
	DC current	l _{dc-gd1} , l _{dc-gd2}	±0.1	A	3
Vref terminal current	I _{ref}	-5	mA	3	
Terminal current	I _{t-group}	±1	mA	3, 5	
RS terminal current	I _{rs}	-500	μA	3	
RT terminal current	I _{rt}	-200	μA	3	
IRAMP terminal current	I _{ramp}	-200	μA	3	
BO clamp current	I _{bo}	300	μA	3	
Terminal voltage	V _{t-group}	-0.3 to V _{ref}	V	3, 6	
Vref terminal voltage	V _{t-ref}	-0.3 to V _{ref} +0.3	V	3	
SS terminal voltage	V _{t-ss}	-0.3 to V _{ref} +1	V	3	
Power dissipation	P _t	1	W	3, 7	
Operating junction temperature	T _{j-opr}	-40 to +150	°C		
Storage temperature	T _{stg}	-55 to +150	°C		

- Notes:
- Rated voltages are with reference to the AGND and PGND terminal.
 - For the direction of Rated currents, (+) denotes the current flowing into the IC, and (-) denotes the current flowing out of the IC.
 - Ambience temperature, T_a is 25 degrees centigrade.
 - Transient current when driving a capacitive load.
 - Rated currents of the terminals listed below:
COMP, CSO1, CSO2
 - Rated voltages of the terminals listed below:
in the case of R2A20114AFP: CS1, CS2, VAC, RS, FB, PD, BO, ERROR, E-DLAY, OFF, OVP2, FMC, FMR, RT/SYNC, IRAMP, SYNC-O, CT, COMP, CSO1, CSO2
in the case of R2A20114ASP: CS1, CS2, VAC, RS, FB, BO, IRAMP, FM, RT/SYNC, CT, COMP, CSO1, CSO2
 - Thermal resistor
in the case of R2A20114AFP: θ_{ja} = 85.3 degrees centigrade/W
in the case of R2A20114ASP: θ_{ja} = 120 degrees centigrade/W
These values are obtained under the condition that the IC is mounted on the glass epoxy board, of which size is 50 × 50 × 1.6 [mm] and wiring density is 10%.

Electrical Characteristics

($T_a = 25^\circ\text{C}$, $V_{CC} = 12\text{ V}$, $C_T = 1000\text{ pF}$, $R_T = 27\text{ k}\Omega$, $CS1, CS2 = \text{GND}$, $IRAMP = 10\text{ k}\Omega$, $BO = 1\text{ V}$, $V_{AC} = 0\text{ V}$, $RS = 220\text{ k}\Omega$, $FMC = \text{GND}$ (*¹), $FM = \text{GND}$ (*²), $FB = \text{COMP}$)

Item	Symbol	Min	Typ	Max	Unit	Test Conditions	
Supply	UVLO turn-on threshold	Vuvlh	9.7	10.4	11.1	V	
	UVLO turn-off threshold	Vuvll	8.4	8.9	9.4	V	
	UVLO hysteresis	Hysuvl	1.0	1.5	2.0	V	
	Standby current	Istby	—	100	160	μA	$V_{CC} = 8.9\text{ V}$
	Operating current	Icc	—	5	7.5	mA	
VREF	Output voltage	Vref	4.85	5.00	5.15	V	Isource = -1 mA
	Line regulation	Vref-line	—	5	20	mV	Isource = -1 mA, $V_{CC} = 10\text{ V to }24\text{ V}$
	Load regulation	Vref-load	—	5	20	mV	Isource = -1 mA to -5 mA
	Temperature stability	dVref	—	± 80	—	ppm/ $^\circ\text{C}$	$T_a = -40\text{ to }125^\circ\text{C}$ (* ³)
Error amplifier	Feedback voltage	Vfb	2.462	2.500	2.538	V	FB-COMP Short
	Input bias current (* ¹)	Ifb	-0.5	-0.3	-0.05	μA	Measured pin: FB
	Input bias current (* ²)	Ifb	-1.3	-0.8	-0.25	μA	Measured pin: FB
	Open loop gain	Av	—	40	—	dB	(* ³)
	Upper clamp voltage	Vclamp-comp	3.8	4.0	4.3	V	FB = 2.0 V, COMP: Open
	Low voltage	Vl-comp	0.0	0.1	0.3	V	FB = 3.0 V, COMP: Open
	Source current	Isrc-comp	-190	-135	-80	μA	FB = 1.5 V, COMP = 2.5 V
	Sink current 1	I _{snk-comp1}	—	120	—	μA	(* ³)
	Sink current 2	I _{snk-comp2}	220	320	420	μA	FB = 3.5 V, COMP = 2.5 V
	Transconductance	gm	120	200	290	μs	FB = 2.45 V \leftrightarrow 2.55 V, COMP = 2.5 V
Brownout	PFC enable voltage	Von-pfc	0.74	0.82	0.9	V	Input pin: BO
	PFC disable voltage	Voff-pfc	0.73	0.81	0.89	V	Input pin: BO
Oscillator	Initial accuracy	fout	70	78	86	kHz	Measured pin: OUT, FMC = 0 V
	fout temperature stability	dfout/dTa	—	± 0.1	—	%/ $^\circ\text{C}$	$T_a = -40\text{ to }125^\circ\text{C}$ (* ³)
	fout voltage stability	fout-line	-1.5	0.5	1.5	%	$V_{CC} = 12\text{ V to }18\text{ V}$
	CT top voltage	Vct-H	—	3.6	4.0	V	(* ³)
	RT voltage	Vrt	1.15	1.25	1.35	V	
	FMC sink current (* ¹)/ FM sink current (* ²)	I _{snk-fmc} (* ¹)/ I _{snk-fm} (* ²)	6	11	16	μA	FMC = 1 V (* ¹)/ FM = 1 V (* ²)
	FMC source current (* ¹)/ FM source current (* ²)	I _{src-fmc} (* ¹)/ I _{src-fm} (* ²)	-16.5	-11.5	-6.5	μA	FMC = 1 V (* ¹)/ FM = 1 V (* ²)
	FM magnitude change	dfm	19	24	29	kHz	FMC = 5 V (* ¹)/FM = 5 V (* ²) (* ³ , * ⁴)
	FM frequency 1 (* ¹)	ffm1	0.25	0.38	0.5	kHz	FMC = 6.8 nF, FMR = 4 V (* ⁴)
	FM frequency 2 (* ¹)	ffm2	14	25	35	kHz	FMC = 220 pF, FMR = 1.2 V (* ⁴)
	FM frequency (* ²)	ffm	6	10	14	kHz	FM = 220 pF (* ⁴)

Notes: *1 Applied to R2A20114AFP

*2 Applied to R2A20114ASP

*3 Design Specification (Reference data)

*4 Refer to the figure shown below:

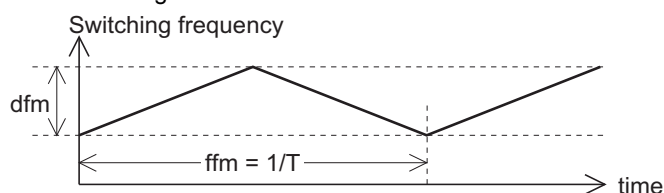

Electrical Characteristics (cont.)

(Ta = 25°C, VCC = 12 V, CT = 1000 pF, RT = 27 kΩ, CS1, CS2 = GND, IRAMP = 10 kΩ, BO = 1 V, VAC = 0 V, RS = 220 kΩ, FMC = GND (*¹), FM = GND (*²), FB = COMP)

Item	Symbol	Min	Typ	Max	Unit	Test Conditions	
Synchroni- zation	SYNC threshold voltage (rising)	Vsync	2.0	2.5	3.0	V	
	SYNC Min. pulse	Psync	2	—	—	μs	
	SYNC-OUT shunt current (* ¹)	Isync-s	5.0	—	—	mA	
	SYNC-OUT leakage current (* ¹)	Isync-l	—	—	1.0	μA	
Current slope	RS output voltage 1	Vrs1	0.42	0.51	0.6	V	VAC = 0 V, VOVP2 = 2.5 V
	RS output voltage 2	Vrs2	-0.1	0	0.1	V	VAC = 2.5 V, VOVP2 = 0 V
	VAC bias current	Ivac	-0.8	-0.5	-0.2	μA	Measured pin: VAC
Soft start	Source current	Iss	-40	-28	-16	μA	SS = 2 V
Phase drop	Phase drop threshold voltage (* ¹)	Vpd	2.4	2.5	2.6	V	
	Phase drop hysteresis (* ¹)	Hya-pd	150	200	250	mV	
	PD bias current (* ¹)	Ipd	0.05	0.2	0.5	μA	Measured pin: PD
AMP1, 2	CSO offset voltage1	Voffset	0.68	0.88	1.0	V	Vcs = 0 V
	CSO offset voltage2	Vcaoh	2.83	3	3.17	V	Vcs = 0.24 V
	CS Bias current	Ics-r	-0.4	-0.2	-0.05	μA	Measured pin: CS1, 2
Gate drive 1, 2	Gate drive rise time	tr-gd	—	30	100	ns	CL = 500 pF
	Gate drive fall time	tf-gd	—	30	100	ns	CL = 500 pF
	Gate drive low voltage	Vol1-gd	—	0.05	0.2	V	Isink = 10 mA
		Vol2-gd	—	1	1.25	V	Isink = 0.25 mA, VCC = 5 V
	Gate drive high voltage	Voh-gd	11.5	11.9	—	V	Isource = -10 mA
	Minimum duty cycle	Dmin-out	—	—	0	%	
Maximum duty cycle	Dmax-out	90	95	98	%		
Over voltage protection	Dynamic OVP Threshold voltage	Vdovp	VFB× 1.025	VFB× 1.040	VFB× 1.055	V	
	Static OVP Threshold voltage	Vsovp	VFB× 1.065	VFB× 1.080	VFB× 1.095	V	COMP = OPEN
	Static OVP Hysteresis	Hys-sovp	30	80	130	mV	COMP = OPEN
	OVP2 Threshold voltage (* ¹)	Vovp2	VFB× 1.065	VFB× 1.080	VFB× 1.095	μA	
	OVP2 Hysteresis (* ¹)	Hys-ovp2	30	80	130	mV	COMP = OPEN
	OVP2 Bias current (* ¹)	Iovp2	-0.8	-0.5	-0.2	μA	Measured pin: OVP2
	FB Open Detect Threshold voltage	Vfbopen	0.45	0.5	0.55	V	
	FB Open Detect hysteresis	Vfbopen	0.16	0.2	0.24	V	
Over current protection	OCP Threshold voltage (* ¹)	VCL	0.28	0.31	0.34	V	
	Delay to output	td-CL	—	100	250	ns	

Notes: *1 Applied to R2A20114AFP

*2 Applied to R2A20114ASP

Electrical Characteristics (cont.)

(Ta = 25°C, VCC = 12 V, CT = 1000 pF, RT = 27 kΩ, CS1, CS2 = GND, IRAMP = 10 kΩ, BO = 1 V, VAC = 0 V, RS = 220 kΩ, FMC = GND (*1), FM = GND (*2), FB = COMP)

Item	Symbol	Min	Typ	Max	Unit	Test Conditions	
Error signal	ERROR shunt current (*1)	5.0	—	—	mA		
	ERROR leakage current (*1)	—	—	1.0	μA		
	Phase error detect point	Perror	1.1	1.35	1.6	—	Vcso1 or 2 = 2.5 V, Vcso2 or 1: sweep (*5)
	OFF threshold voltage (*1)	Voff	3.3	4.0	4.7	V	
	E-DELAY charge current (*1)	led-c	-55	-36	-20	μA	
	E-DELAY discharge current (*1)	led-d	20	36	55	μA	
	E-DELAY threshold voltage (*1)	Vdelay	2.35	2.45	2.55	V	

Notes: *1 Applied to R2A20114AFP

*2 Applied to R2A20114ASP

*5 Refer to the figure shown below:

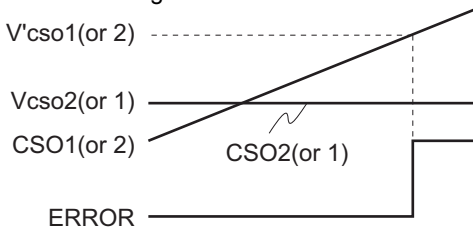

$$P_{error} = \frac{V'cso1(or 2)[V] - 0.55[V]}{Vcso2(or 1)[V] - 0.55[V]}$$

Timing Chart

1. Vcc Start-up and Stop Timing

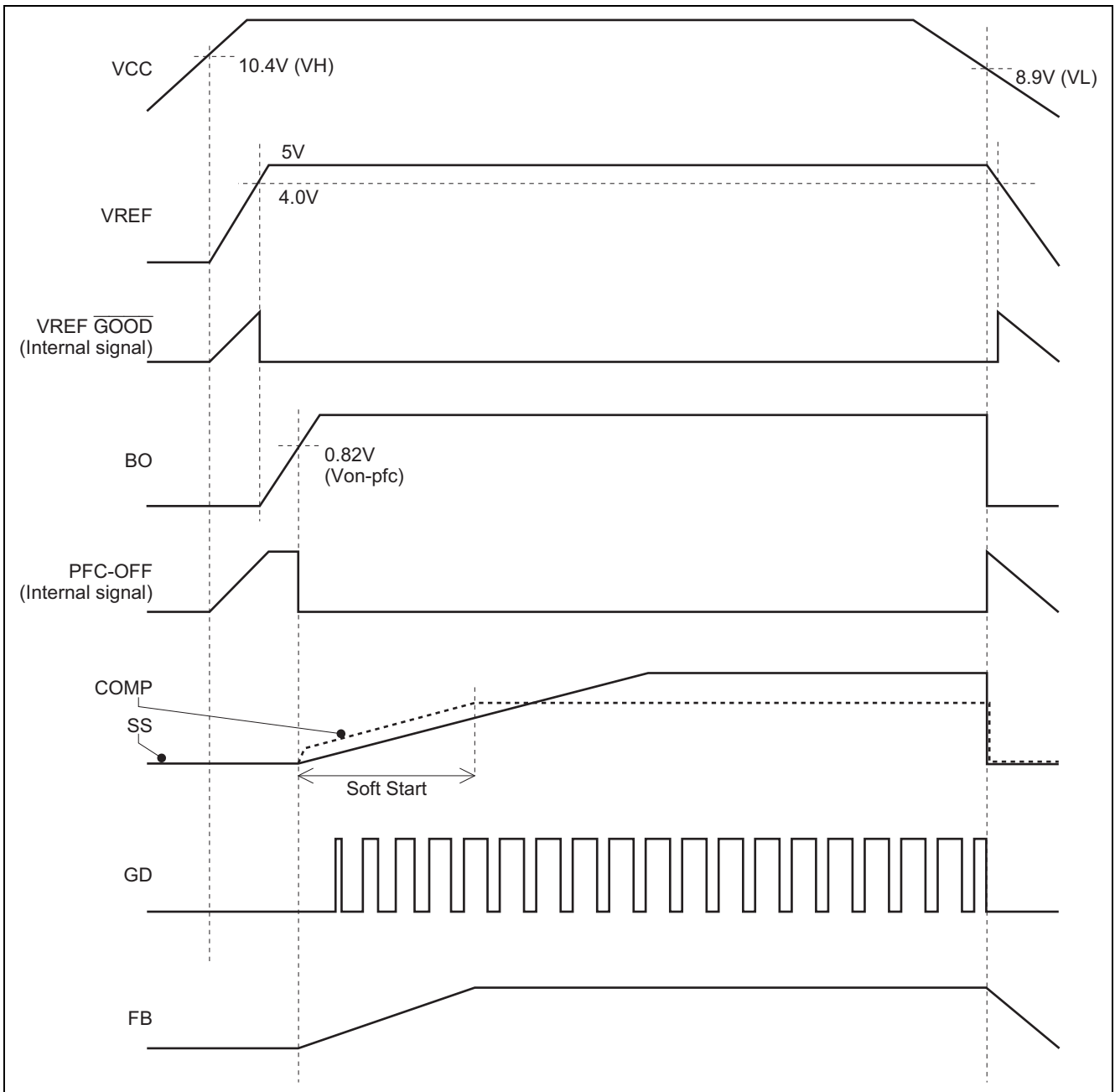

2. Stop Timing

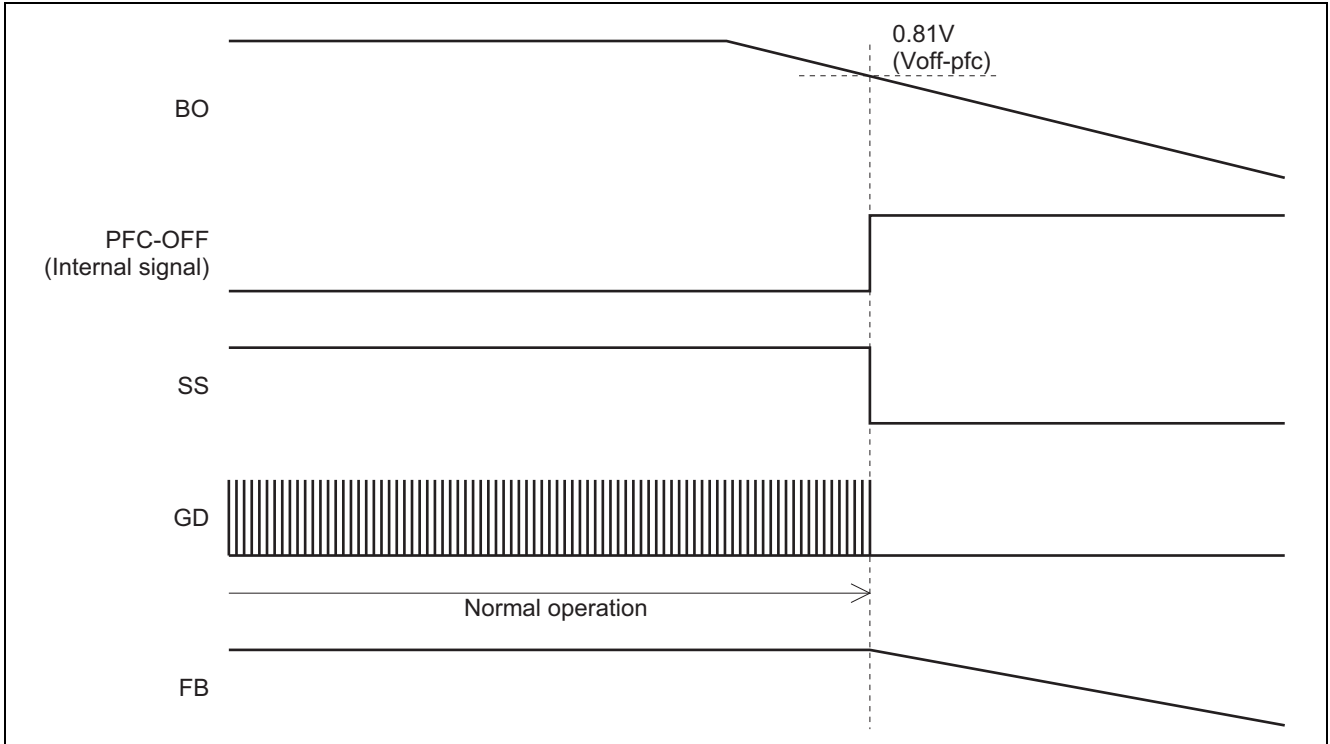

3. Overvoltage Protection (OVP)

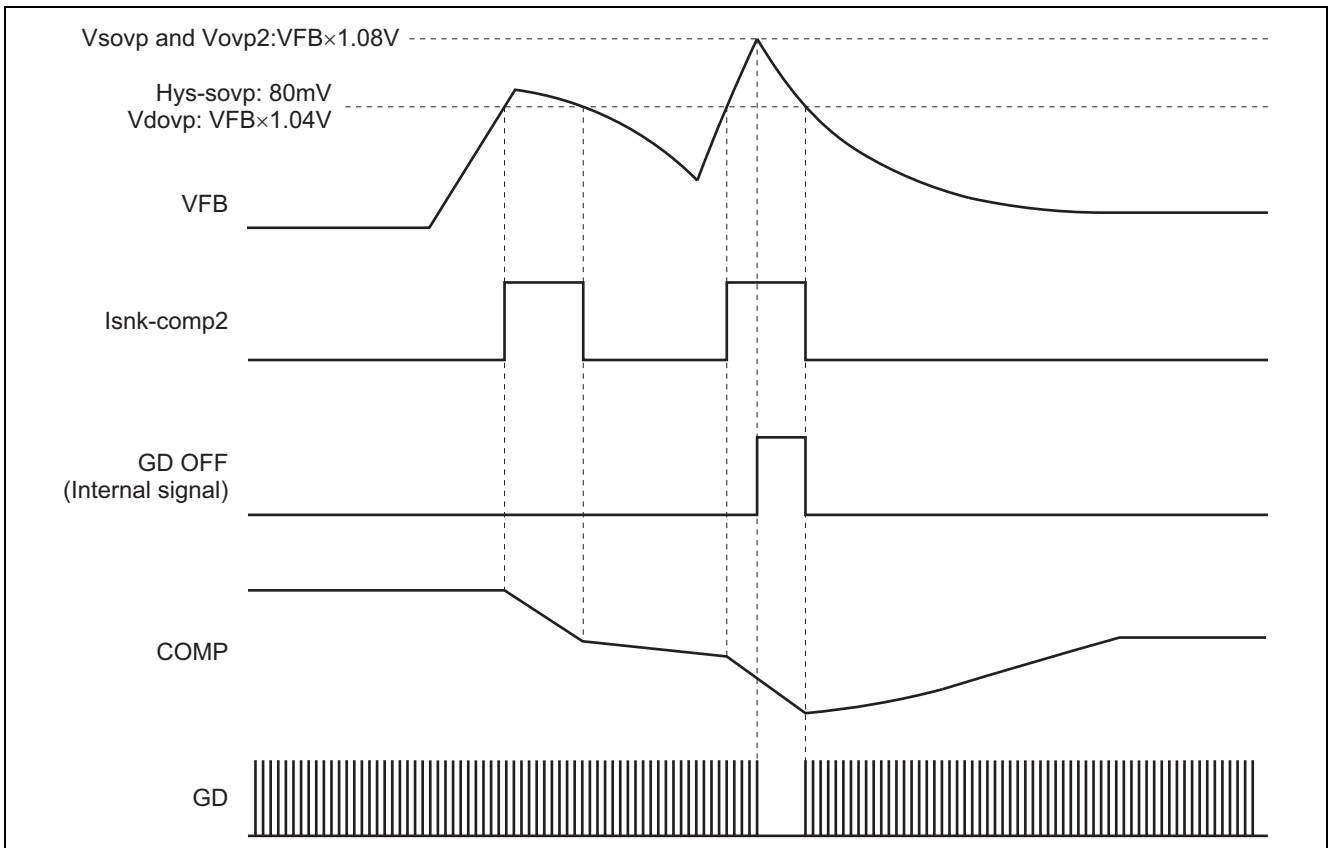

4. Phase Drop (Applied to R2A20114AFP)

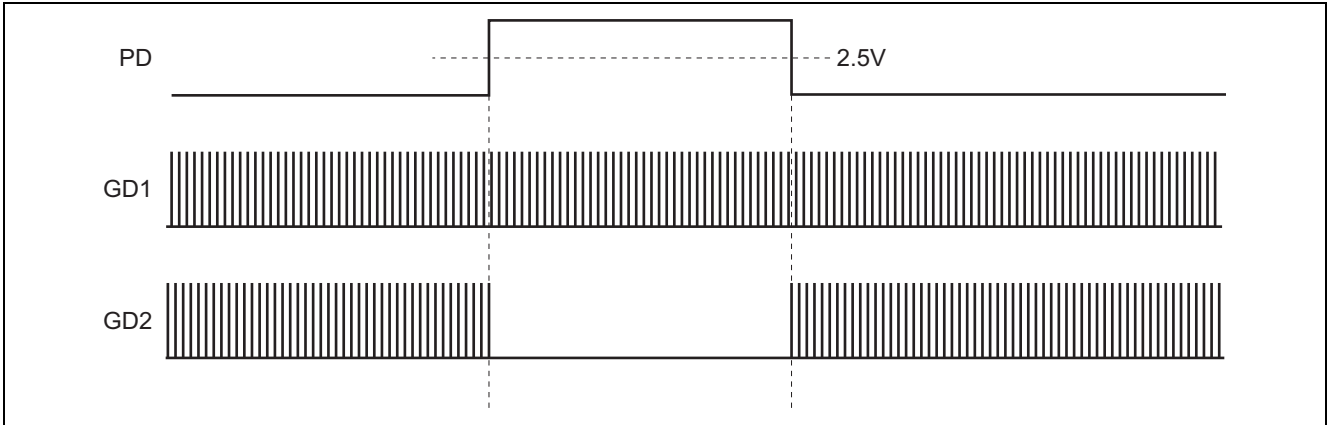

5. ERROR (Applied to R2A20114AFP)

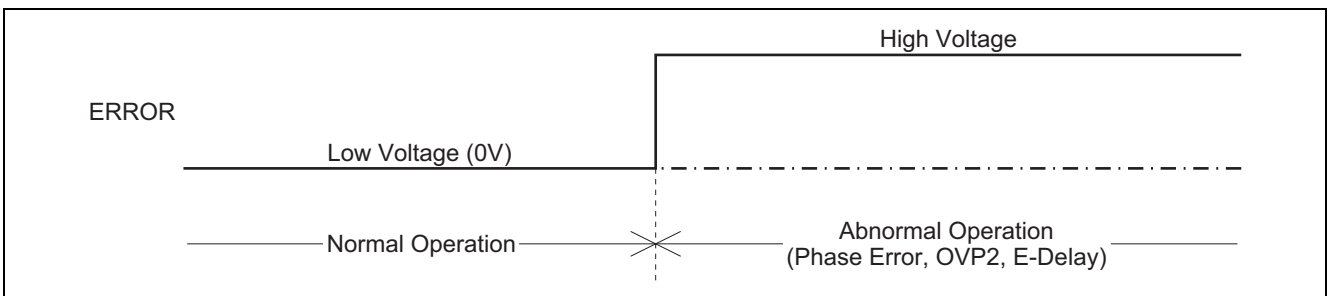

System Diagram (Applied to R2A20114ASP)

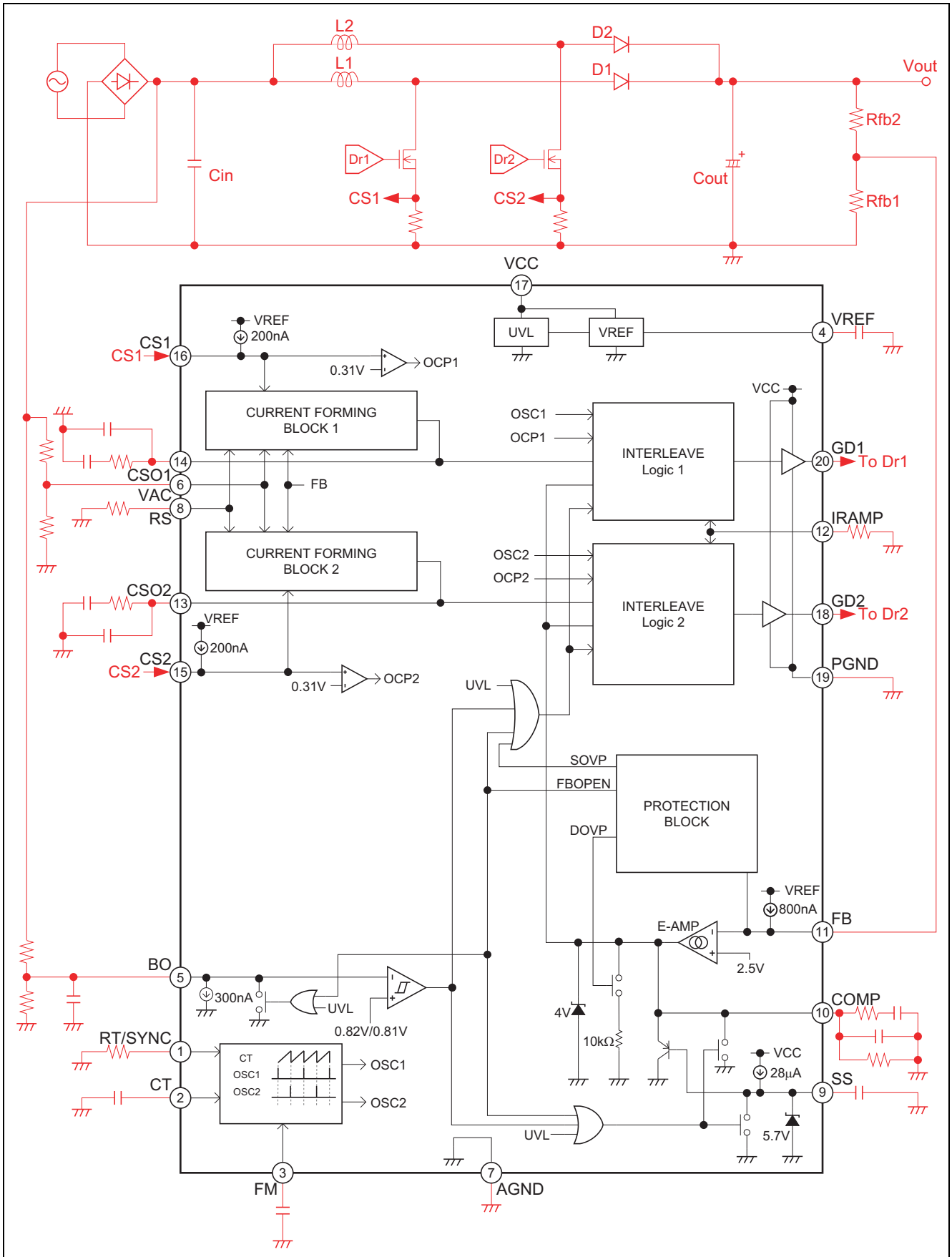

Package Dimensions

• R2A20114AFP

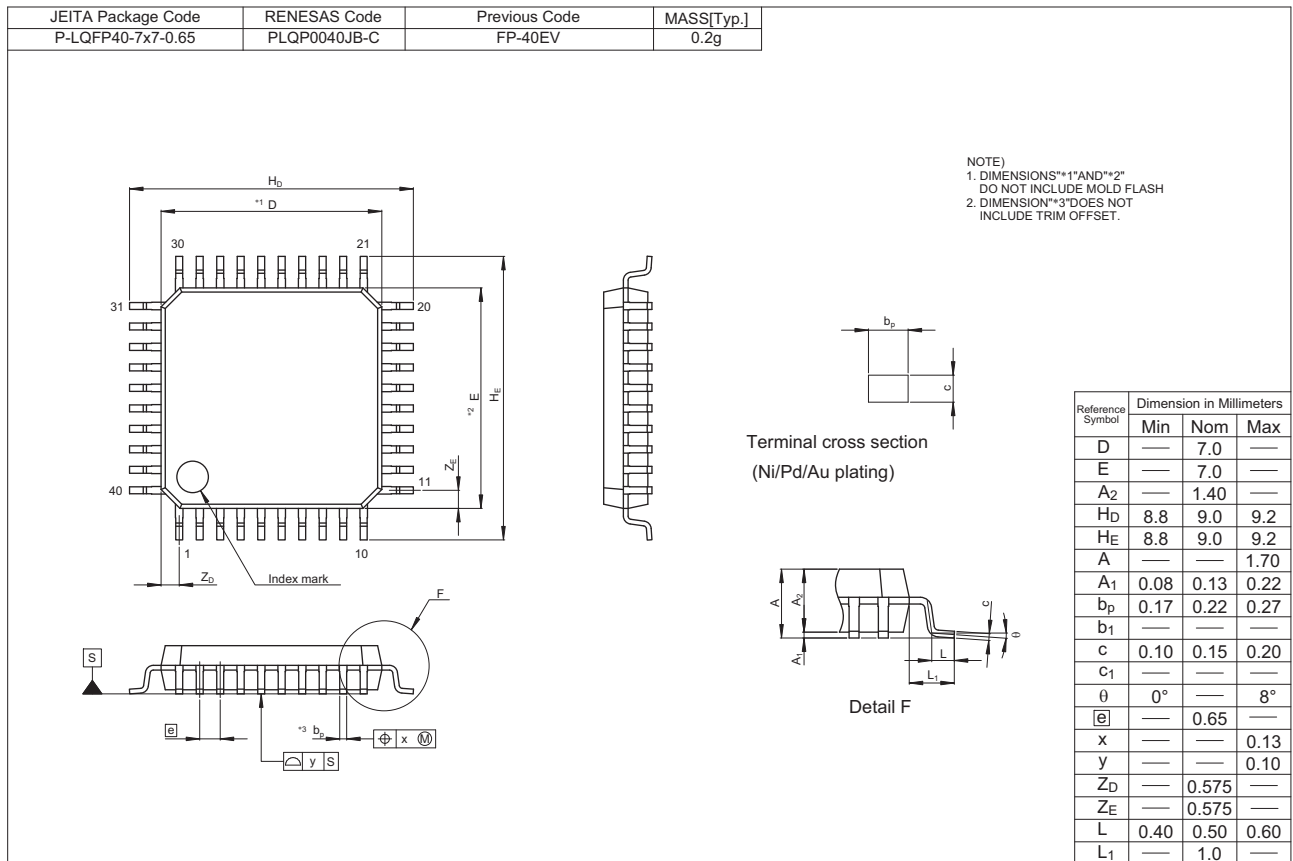

• R2A20114ASP

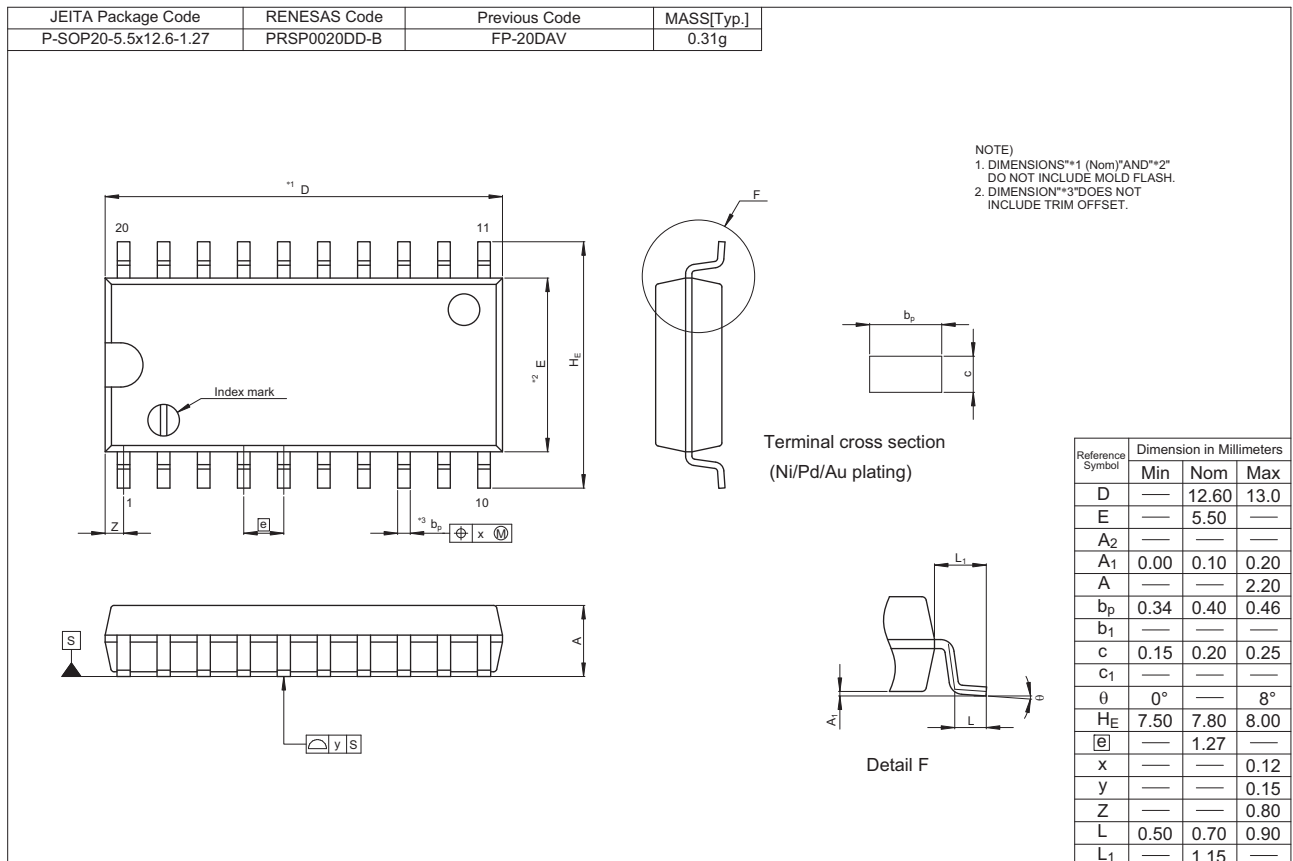

Notice

- All information included in this document is current as of the date this document is issued. Such information, however, is subject to change without any prior notice. Before purchasing or using any Renesas Electronics products listed herein, please confirm the latest product information with a Renesas Electronics sales office. Also, please pay regular and careful attention to additional and different information to be disclosed by Renesas Electronics such as that disclosed through our website.
- Renesas Electronics does not assume any liability for infringement of patents, copyrights, or other intellectual property rights of third parties by or arising from the use of Renesas Electronics products or technical information described in this document. No license, express, implied or otherwise, is granted hereby under any patents, copyrights or other intellectual property rights of Renesas Electronics or others.
- You should not alter, modify, copy, or otherwise misappropriate any Renesas Electronics product, whether in whole or in part.
- Descriptions of circuits, software and other related information in this document are provided only to illustrate the operation of semiconductor products and application examples. You are fully responsible for the incorporation of these circuits, software, and information in the design of your equipment. Renesas Electronics assumes no responsibility for any losses incurred by you or third parties arising from the use of these circuits, software, or information.
- When exporting the products or technology described in this document, you should comply with the applicable export control laws and regulations and follow the procedures required by such laws and regulations. You should not use Renesas Electronics products or the technology described in this document for any purpose relating to military applications or use by the military, including but not limited to the development of weapons of mass destruction. Renesas Electronics products and technology may not be used for or incorporated into any products or systems whose manufacture, use, or sale is prohibited under any applicable domestic or foreign laws or regulations.
- Renesas Electronics has used reasonable care in preparing the information included in this document, but Renesas Electronics does not warrant that such information is error free. Renesas Electronics assumes no liability whatsoever for any damages incurred by you resulting from errors in or omissions from the information included herein.
- Renesas Electronics products are classified according to the following three quality grades: "Standard", "High Quality", and "Specific". The recommended applications for each Renesas Electronics product depends on the product's quality grade, as indicated below. You must check the quality grade of each Renesas Electronics product before using it in a particular application. You may not use any Renesas Electronics product for any application categorized as "Specific" without the prior written consent of Renesas Electronics. Further, you may not use any Renesas Electronics product for any application for which it is not intended without the prior written consent of Renesas Electronics. Renesas Electronics shall not be in any way liable for any damages or losses incurred by you or third parties arising from the use of any Renesas Electronics product for an application categorized as "Specific" or for which the product is not intended where you have failed to obtain the prior written consent of Renesas Electronics. The quality grade of each Renesas Electronics product is "Standard" unless otherwise expressly specified in a Renesas Electronics data sheets or data books, etc.
"Standard": Computers; office equipment; communications equipment; test and measurement equipment; audio and visual equipment; home electronic appliances; machine tools; personal electronic equipment; and industrial robots.
"High Quality": Transportation equipment (automobiles, trains, ships, etc.); traffic control systems; anti-disaster systems; anti-crime systems; safety equipment; and medical equipment not specifically designed for life support.
"Specific": Aircraft; aerospace equipment; submersible repeaters; nuclear reactor control systems; medical equipment or systems for life support (e.g. artificial life support devices or systems), surgical implantations, or healthcare intervention (e.g. excision, etc.), and any other applications or purposes that pose a direct threat to human life.
- You should use the Renesas Electronics products described in this document within the range specified by Renesas Electronics, especially with respect to the maximum rating, operating supply voltage range, movement power voltage range, heat radiation characteristics, installation and other product characteristics. Renesas Electronics shall have no liability for malfunctions or damages arising out of the use of Renesas Electronics products beyond such specified ranges.
- Although Renesas Electronics endeavors to improve the quality and reliability of its products, semiconductor products have specific characteristics such as the occurrence of failure at a certain rate and malfunctions under certain use conditions. Further, Renesas Electronics products are not subject to radiation resistance design. Please be sure to implement safety measures to guard them against the possibility of physical injury, and injury or damage caused by fire in the event of the failure of a Renesas Electronics product, such as safety design for hardware and software including but not limited to redundancy, fire control and malfunction prevention, appropriate treatment for aging degradation or any other appropriate measures. Because the evaluation of microcomputer software alone is very difficult, please evaluate the safety of the final products or system manufactured by you.
- Please contact a Renesas Electronics sales office for details as to environmental matters such as the environmental compatibility of each Renesas Electronics product. Please use Renesas Electronics products in compliance with all applicable laws and regulations that regulate the inclusion or use of controlled substances, including without limitation, the EU RoHS Directive. Renesas Electronics assumes no liability for damages or losses occurring as a result of your noncompliance with applicable laws and regulations.
- This document may not be reproduced or duplicated, in any form, in whole or in part, without prior written consent of Renesas Electronics.
- Please contact a Renesas Electronics sales office if you have any questions regarding the information contained in this document or Renesas Electronics products, or if you have any other inquiries.
(Note 1) "Renesas Electronics" as used in this document means Renesas Electronics Corporation and also includes its majority-owned subsidiaries.
(Note 2) "Renesas Electronics product(s)" means any product developed or manufactured by or for Renesas Electronics.



SALES OFFICES

Renesas Electronics Corporation

<http://www.renesas.com>

Refer to "<http://www.renesas.com/>" for the latest and detailed information.

Renesas Electronics America Inc.
2880 Scott Boulevard Santa Clara, CA 95050-2554, U.S.A.
Tel: +1-408-586-6000, Fax: +1-408-586-6130

Renesas Electronics Canada Limited
1101 Nicholson Road, Newmarket, Ontario L3Y 9C3, Canada
Tel: +1-905-898-5441, Fax: +1-905-898-3220

Renesas Electronics Europe Limited
Dukes Meadow, Millboard Road, Bourne End, Buckinghamshire, SL8 5FH, U.K.
Tel: +44-1628-585-100, Fax: +44-1628-585-900

Renesas Electronics Europe GmbH
Arcadiastrasse 10, 40472 Düsseldorf, Germany
Tel: +49-211-65030, Fax: +49-211-6503-1327

Renesas Electronics (China) Co., Ltd.
7th Floor, Quantum Plaza, No.27 ZhiChunLu Haidian District, Beijing 100083, P.R.China
Tel: +86-10-8235-1155, Fax: +86-10-8235-7679

Renesas Electronics (Shanghai) Co., Ltd.
Unit 204, 205, AZIA Center, No.1233 Lujiazui Ring Rd., Pudong District, Shanghai 200120, China
Tel: +86-21-5877-1818, Fax: +86-21-6887-7858 / -7898

Renesas Electronics Hong Kong Limited
Unit 1601-1613, 16/F., Tower 2, Grand Century Place, 193 Prince Edward Road West, Mongkok, Kowloon, Hong Kong
Tel: +852-2886-9318, Fax: +852 2886-9022/9044

Renesas Electronics Taiwan Co., Ltd.
13F, No. 363, Fu Shing North Road, Taipei, Taiwan
Tel: +886-2-8175-9600, Fax: +886 2-8175-9670

Renesas Electronics Singapore Pte. Ltd.
1 HarbourFront Avenue, #06-10, Keppel Bay Tower, Singapore 098632
Tel: +65-6213-0200, Fax: +65-6276-8001

Renesas Electronics Malaysia Sdn.Bhd.
Unit 906, Block B, Menara Amcorp, Amcorp Trade Centre, No. 18, Jin Persiaran Barat, 46050 Petaling Jaya, Selangor Darul Ehsan, Malaysia
Tel: +60-3-7955-9390, Fax: +60-3-7955-9510

Renesas Electronics Korea Co., Ltd.
11F., Samik Lavied' or Bldg., 720-2 Yeoksam-Dong, Kangnam-Ku, Seoul 135-080, Korea
Tel: +82-2-558-3737, Fax: +82-2-558-5141